

THE Radio Constructor

RADIO
TELEVISION
AUDIO
ELECTRONICS

VOLUME 19 NUMBER 2
A DATA PUBLICATION
TWO SHILLINGS & THREEPENCE

September 1965

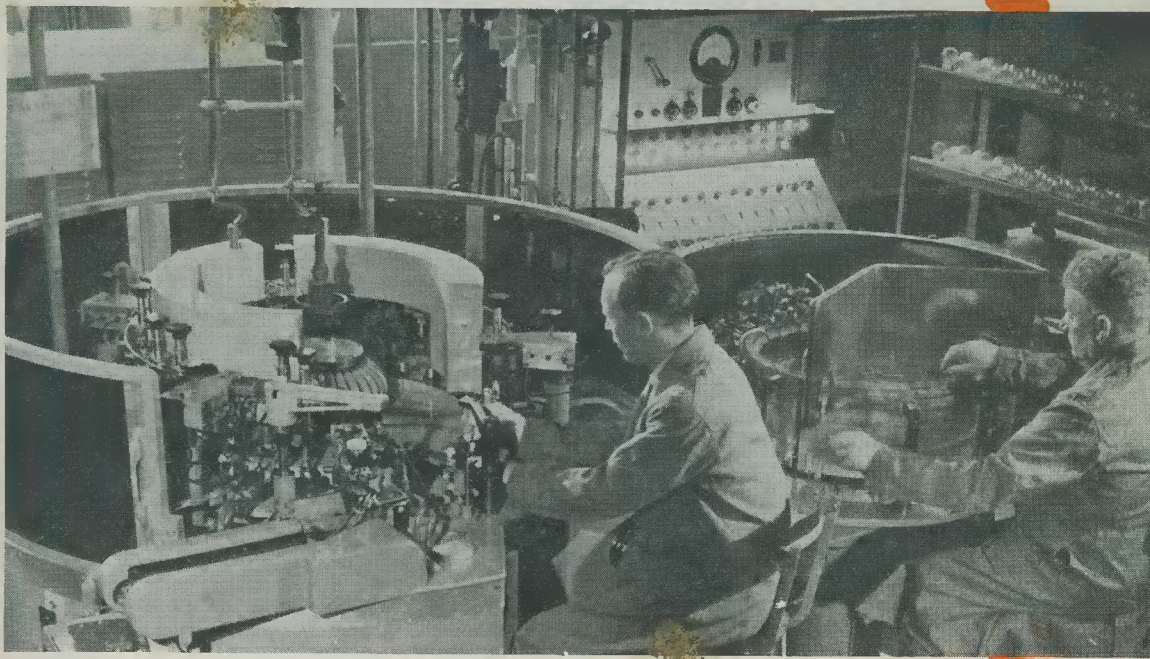

The Story of the Valve

Electronic Counting
with Dekatrons



Quality
Multimeter



Simple Transistor
Tester



Beat Frequency
Audio Oscillator

Scottish Insurance Corporation Ltd

38 EASTCHEAP · LONDON · EC3



TELEVISION SETS, RECEIVERS AND TRANSMITTERS

Television Sets, Receivers and Short Wave Transmitters are expensive to acquire and you no doubt highly prize your installation. Apart from the value of your Set, you might be held responsible should injury be caused by a fault in the Set, or injury or damage by your Aerial collapsing.

A "Scottish" special policy for Television Sets, Receivers and Short Wave Transmitters provides the following cover:

- (a) Loss or damage to installation (including in the case of Television Sets the Cathode Ray Tube) by Fire, Explosion, Lightning, Theft or Accidental External Means at any private dwelling-house.
- (b) (i) Legal Liability for bodily injury to Third Parties or damage to their property arising out of the breakage or collapse of the Aerial Fittings or Mast, or through any defect in the Set. Indemnity £10,000 any one accident.
- (ii) Damage to your property or that of your landlord arising out of the breakage or collapse of the Aerial Fittings or Mast, but not exceeding £500.

The cost of Cover (a) is 5/- a year for Sets worth £50 or less, and for Sets valued at more than £50 the cost is in proportion. Cover (b) (i) and (ii) costs only 2/6 a year if taken with Cover (a), or 5/- if taken alone.

Why not BE PRUDENT AND INSURE your installation—it is well worth while AT THE VERY LOW COST INVOLVED. If you write to the Corporation's Office a proposal will be submitted for completion.

Write for full details, quoting reference J/B, to:—

THE MANAGER
SCOTTISH INSURANCE CORPORATION LTD.,
38 EASTCHEAP, LONDON E.C.3

EXCEL in

RADIO AND ELECTRONICS

AS A CAREER OR AS A FASCINATING HOBBY...

THERE IS AN ICS COURSE FOR YOU!

By taking an ICS specialised home study course you gain a sound theoretical and practical knowledge of valve and transistor circuits and servicing work while building your own 5-valve receiver, transistor portable (or a.f. amplifier), signal generator and multi-test meter. *All under expert tuition!*

ICS Construction Courses have been specially written and designed by experienced radio engineers to enable YOU to learn easily and quickly, in your own home, in your own time.

ICS training will take you from basic principles to advanced applications of various circuits, all made up from the kits supplied.

With the ICS Complete Radio and Electronics Construction Course you get SIX kits, including testing instruments, tools and first class components. And, what is most important, a personal library of Instruction Manuals.

If you are making a career in the Radio Industry, you will be interested in the wide range of examination and specialist diploma courses offered by ICS. These include:

Radio and Television Engineering, Industrial Television, Radio and Television Servicing, Colour Television, Electronic Technicians, Servomechanisms, Radio-Electronic Telemetry, Instrumentation, Principles of Automation, Calculus for Electronics, Digital and Analogue Computers.

Specialised coaching for Grad.I.E.R.E., C.&G. Telecommunication Technician's Cert. Radio & TV Servicing Cert.(R.T.E.B.), P.M.G. Certs. and Radio Amateur's Exam.

Examination students coached until successful

PRACTICAL INSTRUCTION!

1

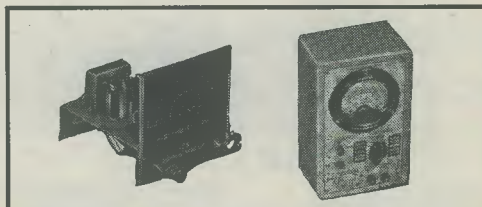

Assembly and use of signal generator and multi-test meter (especially valuable in servicing work).

2

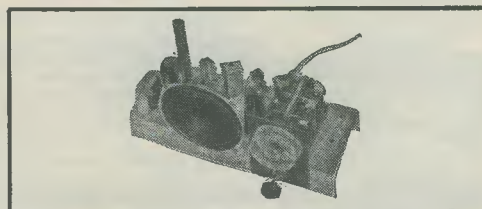

Construction of 5-valve 2-waveband AC/DC super-heterodyne receiver, and a number of instructional experiments, using testing instruments.

3

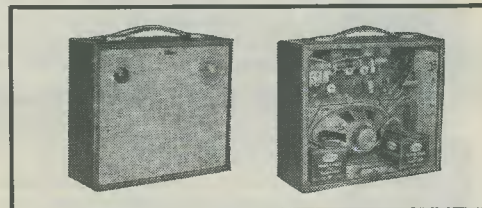

Construction of 6-transistor (with semiconductor diode) 2-waveband portable, and a number of instructional experiments, including a.f. amplifier with microphone pre-amplifier.

For full details
of ICS Radio and
Electronics Courses
post coupon
TODAY

ICS (DEPT. 248) INTERTEXT HOUSE
PARKGATE ROAD, LONDON, S.W.11

NAME

AGE

ADDRESS

9.65

INTERNATIONAL CORRESPONDENCE SCHOOLS

Member of the Association of British Correspondence Colleges



Choose Heathkit models for value and performance

Easy-to-follow instruction manuals tell you how to build any model

HI-FI AMPLIFIERS ~~~~~ TUNERS ~~~~~ RECORD PLAYERS

STEREO AMP. AA-22U



PLAYER AT-6



HI-FI 6W STEREO AMPLIFIER. Model S-33. 3 watts per channel 0.3% distortion at 2.5W/chnl., 20dB N.F.B. Inputs for Radio (or Tape) and Gram. Kit **£13.7.6** Assembled **£18.18.0**

20+20W TRANSISTOR STEREO AMPLIFIER. Model AA-22U. Outstanding performance. Handsome, walnut-veneered cabinet. Kit **£43.18.0** Assembled **£68.16.0**

GARRARD AUTO/RECORD PLAYER. Model AT-6. With R 105 cartridge **£13.12.1** Decca Deram pick-up **£14.6.1** incl. P.T.

HI-FI MONO AMPLIFIER. Model MA-5. A general purpose 5W Amplifier, with inputs for Gram., Radio. Presentation similar to S-33 Kit **£10.19.6** Assembled **£15.10.0**

PA AMPLIFIER, Model PA-1. 50W amplifier. The ideal, compact unit. Two heavy duty speakers. Variable tremolo. Legs optional extra 17/6 Kit **£54.15.0** Assembled **£74.0.0**

POWER AMP. MA-12



STEREO AMP. S-99



HI-FI MONO AMPLIFIER. Model MA-12. 10W output, wide freq. range, low distortion. Kit **£11.18.0** Assembled **£15.18.0**

DE LUXE STEREO AMPLIFIER. Model S-33H. De luxe version of the S-33 with two-tone grey perspex panel, and higher sensitivity necessary to accept the Decca Deram pick-up. Kit **£15.17.6** Assembled **£21.7.6**

HI-FI STEREO AMPLIFIER. Model S-99. 9 + 9W output. Ganged controls. Stereo/Mono gram., radio and tape inputs. Push-button selection Printed circuit construction. Kit **£28.9.6** Assembled **£38.9.6**

POWER SUPPLY UNIT. Model MGP-1. Input 100/120V, 200/250V 40-60 c/s. Output 6.3V, 2.5A A.C. 200, 250, 270V, 120mA max. D.C. Kit **£5.2.6** Assembled **£6.12.6**

HI-FI CABINETS. A wide range available, prices from **£8.8.0** to **£46.4.0** incl. P.T. Assembled or in kit form.

NEW MODEL !



TM-1

TRANSISTOR MIXER. Model TM-1. A must for the tape enthusiast. 7 transistor circuit, battery operation allows unit to be used in or out of doors. Beautiful walnut-veneered cabinet. Presentation similar to the AA-22U Amplifier.

Kit **£11.16.6** Assembled **£16.17.6**

TRANSISTOR RECEIVERS

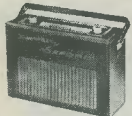

UXR-2

"OXFORD" LUXURY PORTABLE. Model UXR-2. Specially designed for use as a domestic, car or personal portable receiver. Many features, including solid leather case. Kit **£14.18.0** incl. P.T.



UXR-1

TRANSISTOR PORTABLE. Model UXR-1. Pre-aligned I.F. transformers, printed circuit. Covers L.W. and M.W. Has 7" x 4" loudspeaker. Real hide case. Kit **£12.11.0** incl. P.T.



UJR-1

JUNIOR EXPERIMENTAL WORKSHOP. Model EW-1. More than a toy! Will make over 20 exciting electronic devices, incl: Radios, Burglar Alarms, etc. 72 page Manual. The ideal present! Kit **£7.13.6** incl. P.T.

JUNIOR TRANSISTOR RADIO. Model UJR-1. Single transistor set. Excellent introduction to radio. Kit **£2.7.6** incl. P.T.

MANY OTHER BRITISH MODELS

Covering a wide range of models for the home, workshop or service bench or laboratory. Why not send for Free Catalogue ?

INSTRUMENTS

DE LUXE LARGE-SCALE VALVE VOLT-METER: Model IM-13U. Circuit and specification based on the well-known model V-7A but with many worth-while refinements. 6" Ernest Turner meter. Unique gimbal bracket allows operation of instrument in many positions. Modern styling. Kit **£18.18.0** Assembled **£26.18.0**

AUDIO SIGNAL GENERATOR. Model AG-9U. 10 c/s to 100 kc/s, switch selected. Distortion less than 0.1%, 10V sine wave output metered in volts and dB's. Kit **£22.10.0** Assembled **£30.10.0**

VALVE VOLTMETER. Model V-7A. 7 voltage ranges d.c. volts to 1,500. A.c. to 1,500 r.m.s. and 4,000 peak to peak. Resistance 0.1Ω to 1,000MΩ with internal battery. D.c. input resistance 11MΩ. dB measurement, has centre-zero scale. Complete with test prods, leads and standardising battery. Kit **£13.18.6** Assembled **£19.18.6**

MULTIMETER. Model MM-1U. Ranges 0-1.5V to 1,500V a.c. and d.c.; 150μA to 15A d.c.; 0.2Ω to 20MΩ. 4 1/2" 50μA meter. Kit **£12.18.0** Assembled **£18.11.6**

R.F. SIGNAL GENERATOR. Model RF-1U. Up to 100 Mc/s fundamental and 200 Mc/s on harmonics. Up to 100mV output. Kit **£13.8.0** Assembled **£19.18.0**

T.V. ALIGNMENT GENERATOR. Model HFW-1. Offers max performance at lowest cost. Covers 3.6 to 220 Mc/s fundamentals. Electronic sweep oscillators. Built in marker generators (5 Mc/s crystal). Kit **£37.18.0** Kit **£47.10.0** Assembled

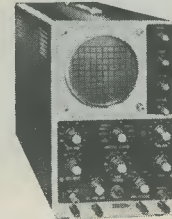

IO-12U

5" GENERAL-PURPOSE LABORATORY OSCILLOSCOPE. Model IO-12U. This outstanding oscilloscope, with its professional specification and styling fulfils most laboratory and service requirements. Vertical frequency response 3 c/s to over 4.5 Mc/s, sensitivity 10mV r.m.s. per cm. at 1 kc/s. T/B covers 10 c/s to 500 kc/s. Kit **£35.17.6** Assembled **£45.15.0**

2 1/2" PORTABLE SERVICE 'SCOPE. Model OS-1. This is a light, compact oscilloscope, ideal for servicing, etc. Dimensions 5" x 8" x 1 1/4" long. Wt. 10 1/2 lb. Fitted metal CRT shield. Kit **£22.18.0** Assembled **£30.8.0**

ELECTRONIC SWITCH. Model S-3U. Converts a single beam 'scope to double beam operation at low cost. Kit **£12.18.0** Assembled **£18.10.0**

TRANSISTOR POWER SUPPLY Model IP-20U. Up to 50V, 1.5A output. Ideal for Laboratory use. Kit **£35.8.0** Assembled **£47.8.0**

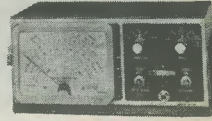

IM-13U



V-7A



RF-1U

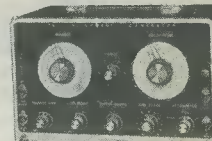

HFW-1

Enjoy Yourself and Save Money with these Kits

No previous experience required to build any Heathkit model



TAPE AMPLIFIERS — TAPE DECKS — CONTROL UNITS

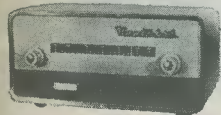

FM
TUNER
FM-4U

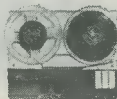

MAGNAVOX
NEW
DECK

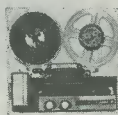

TRUVOX
DECK



AM/FM
TUNER

HI-FI FM TUNER. Model FM-4U. Also available in two units. R.F. tuning unit (£2.15.0 incl. P.T.) with I.F. output of 10.7 Mc/s, and I.F. amplifier unit, with power supply and valves (£13.13.0).

Total Kit **£16.8.0**

MAGNAVOX NEW TAPE DECK. The finest buy in its price range. Operating speeds: 1½", 3½" and 7½" p.s. Two tracks, "wow" and "flutter" not greater than 0.15% at 7½" p.s.

£14.19.6

HI-FI AM/FM TUNER: Model AFM-1. Available in two units which, for your convenience, are sold separately. Tuning heart (AFM-T1—£4.13.6 incl. P.T.) and I.F. amplifier (AFM-A1—£22.11.6). Printed circuit board, 8 valves. Covers L.W., M.W., S.W., and F.M. Built-in power supply.

Total Kit **£27.5.0**

TRUVOX D-93 TAPE DECKS. High quality stereo/mono tape decks. D93/2, ¼ track, £36.15.0 D93/4, ¼ track, £36.15.0

TAPE RECORDING/PLAYBACK AMPLIFIER. Thermometer type recording indicators, press-button speed compensation and input selection. Mono Model TA-1M. Kit **£19.18.0** Assembled **£28.18.0**
Stereo Model TA-1S. Kit **£25.10.0** Assembled **£35.18.0**

MONO CONTROL UNIT. Model UMC-1. Designed to work with the MA-12 or similar amplifier requiring 0.25V or less for full output. 5 inputs. Baxandall type controls. Kit **£8.12.6** Assembled **£13.12.6**

STEREO CONTROL UNIT. Model USC-1. Push-button selection, accurately matched ganged controls to ±1dB. Rumble and variable low-pass filters. Printed circuit boards. Kit **£19.10.0** Assembled **£26.10.0**

SPEAKER SYSTEMS

HI-FI SPEAKER SYSTEM. Model SSU-1. Ducted-port bass reflex cabinet "in the white". Two speakers. Vertical or horizontal models with legs, Kit **£12.12.0**, without legs, Kit **£11.17.6** incl. P.T.

COTSWOLD "MFS" SYSTEM. Designed to give best possible results where floor space is at a premium. This minimum floor space model is based on standard Cotswold. Size: 36" high x 16½" wide x 14½" deep.

Kit **£25.12.0** Assembled **£33.17.0**

THE "COTSWOLD". This is an acoustically designed enclosure 26" x 23" x 15½" housing a 12" bass speaker with 2" speech coil, elliptical middle speaker together with a pressure unit to cover the full frequency range of 30-20,000 c/s. Capable of doing justice to the finest programme source, its polar distribution makes it ideal for really Hi-Fi Stereo.

Kit **£25.12.0** Assembled **£33.17.0**



SSU-1

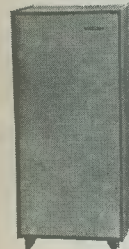

MFS

NEW MODELS

TRANSISTOR TESTER IM-30U

Provides complete d.c. analysis of PNP and NPN transistors and diodes. Kit **£24.18.0**
Assembled **£35.10.0**



IM-30U

HARMONIC DIST. METER IM-12U

Freq. coverage 20-20,000 c/s. Dist. ranges 1, 3, 10, 30, 100% f.s.d. VM ranges 0, 1, 3, 10, 30 volts f.s.d. Input Resistance 300kΩ. Kit **£24.15.0**
Assembled **£34.0.0**

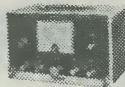

IM-12U

SEND FOR FREE BRITISH HEATHKIT CATALOGUE

American catalogue also available 1/- post paid

Deferred terms available in U.K. over £10.
Extended terms over £75. Send for details.

DAYSTROM LTD DEPT. RC.9
GLOUCESTER

"AMATEUR" EQUIPMENT

AMATEUR BANDS RECEIVER. Model RA-1. To cover all the Amateur Bands from 160-10 metres. Many special features, including: half-lattice crystal filter; 8 valves; signal strength "S" meter; tuned R.F. Amp. stage.

Kit **£39.6.6** Assembled **£52.10.0**

THE "MOHICAN" GENERAL COVERAGE RECEIVER. Model GC-1U. With 4 piezo-electric transmitters, variable tuned B.F.O. and Zener diode stabiliser, this is an excellent fully transistorised general purpose receiver for Amateur and Short wave listeners. Printed circuits, telescopic aerial, tuning meter and large slide-rule dial.

Kit **£37.17.6** Assembled **£45.17.6**

160-10M TRANSMITTER. Model DX-100U. Careful design has achieved high performance and stability. Completely self-contained.

Kit **£79.10.0** Assembled **£104.15.0**

COMMUNICATIONS TYPE RECEIVER. Model RG-1. A high performance, low cost receiver for the discriminating listener. Frequency coverage: 600 kc/s-1.5 Mc/s and 1.7 Mc/s-32 Mc/s.

Kit **£39.16.0** Assembled **£53.0.0**

REFLECTED POWER METER and SWR BRIDGE. Model HM-11U. Indicates reliably, but inexpensively, whether the RF power output of your TX is being transferred efficiently to radiating antenna.

Kit **£8.5.0** Assembled **£10.10.0**



RA-1

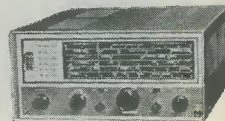

GC-1U

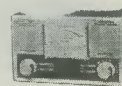

DX-100U



RG-1



HM-11U

AMERICAN HEATHKIT "AMATEUR" EQUIPMENT

A wide range of American Amateur SSB equipment is now available in the U.K. Why not send for full details of range, for example:

80-10M RECEIVER. Model SB-300E.

Of advanced design employing up-to-date construction techniques, its specification ensures unparalleled performance.

Kit **£133.14.0** (less speaker) + import levy



SB-300E

Without obligation please send me
FREE BRITISH HEATHKIT CATALOGUE

FULL DETAILS OF MODEL(S)
(Please write in BLOCK CAPITALS)

NAME

ADDRESS

(Tick here)

DEPT. RC.9



in step with the

20 WATTS R.M.S.

SIZE: 8 $\frac{1}{4}$ " x 3 $\frac{1}{4}$ " x 1"

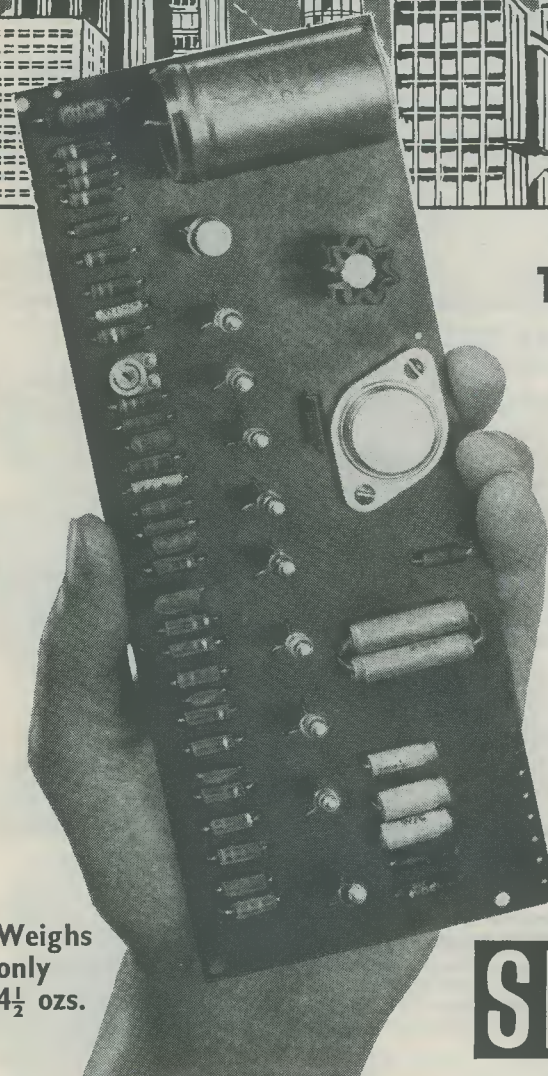

Weights only 4 $\frac{1}{2}$ ozs.

THE NEW APPROACH TO BETTER SOUND

In kit form or ready built

With the SINCLAIR X-20, power is no longer a problem of heat and size, for it requires neither heatsink nor special ventilation. The X-20 will deliver up to 20 watts R.M.S. into a 7 $\frac{1}{2}$ -8 ohms loudspeaker—40 watts output by U.S.A. standards! With the 3-stage integrated pre-amplifier an overall frequency response from 20 to 20,000 c/s well within ± 1 dB from input to output is achieved. There is also greatly improved transient response. At no point are components over-run. The instrument is both stable and assured of indefinite working life—and it is easier to build and install than any amplifier you have ever owned. Best of all the X-20 costs far less.

The only amplifier in the world to feature

- ★ Easily built in an evening
- ★ No. of transistors—12
- ★ Output stage—silicon epitaxial planars
- ★ Constant square wave amplitude
- ★ 95% energy conversion at output
- ★ Superb quality and reliability
- ★ Frequency response—from 20 to 20,000 c/s ± 1 dB
- ★ Total harmonic distortion—0.1% at 10 watts R.M.S.
- ★ Input sensitivity—1mV into 5k Ω
- ★ Signal to noise ratio—better than 70dB
- ★ Output into 7.5 ohms—20 watts R.M.S. music power 15 watts R.M.S. continuous
- ★ Output into 15 ohms—15 watts R.M.S. music value 10 watts R.M.S. continuous
- ★ Makes an ideal guitar or P.A. amplifier
- ★ Wide tolerance to load at output
- ★ Requires 36V d.c. at 700mA
- ★ Add tone and volume control systems for mono or stereo to choice

SINCLAIR X-20

Complete kit of parts inc. transistors and X-20 manual in sealed carton

£7.19.6

Built and tested with X-20 manual in sealed carton

£9.19.6

X-20 Power Pack sufficient to drive two X-20's

£4.19.6

THE X-20 MANUAL

Details in full tone and volume control systems to suit the equipment you use with your X-20. Includes stereo, stereo balance and input switching. FREE with all X-20 amplifiers. Available separately 2/- post free.



SINCLAIR RADIONICS LTD.,
COMBERTON, CAMBRIDGE Telephone: COMBERTON 682

SPACE AGE!

Every constructor should build it
**THE SMALLEST RADIO SET
 IN THE WORLD**

SINCLAIR MICRO-6

Fantastic range and power

No set in the history of radio has ever captured constructors' enthusiasm as has the world-famous Sinclair Micro-6. Never was a set so small, never so efficient and powerful. Smaller than a matchbox, the Micro-6 brings in stations from all over Europe and afar for your pleasure and entertainment. It performs with fantastic efficiency in cars, buses, trains as well as steel-framed buildings, yet everything to do with this set except the lightweight earpiece is contained in the minute white, gold and black case, size $1\frac{4}{5}'' \times 1\frac{3}{10}'' \times \frac{1}{2}''$. The many attractive features include a highly stable 6-stage circuit, powerful A.G.C., bandspread for easy Luxembourg reception, vernier-type tuning over the medium wave-band, and three special M.A.T. Transistors.

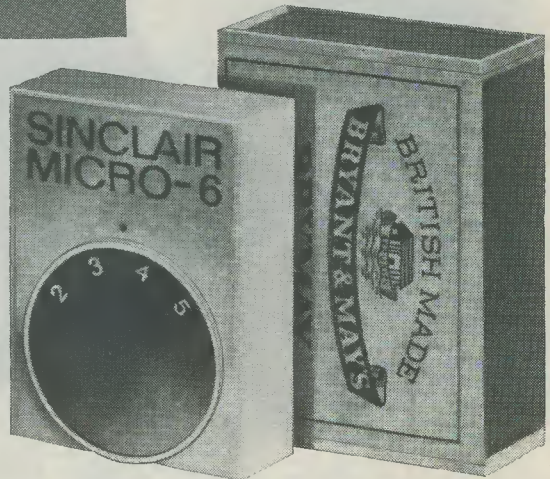

Build it in a single evening!

All parts including lightweight earpiece case and dial, and exceptionally well prepared 8-page instruction manual come to **59/6** Mollory Mercury Cell Type ZM312 (2 required) each 1/11: Pack of 6, 10/6 Sinclair "Transista" well-styled, strong black nylon wrist strap, 7/6.

A POWER AMPLIFIER FOR YOUR MICRO-6

SINCLAIR TR750

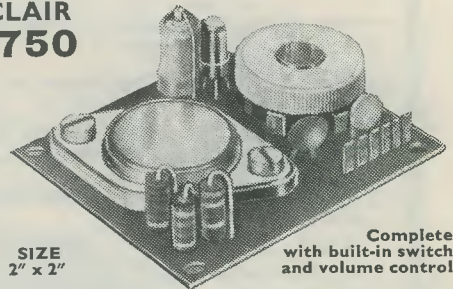

SIZE
2" x 2"

Complete
with built-in switch
and volume control

Designed principally for use with the Micro-6, with which it will make a powerful and efficient car, portable or indoor domestic loudspeaker set, this amplifier will also make a mono or stereo record player, an intercom system, baby alarm, etc.

With built-in switch and volume control. Output 750mW for feeding into standard 25 to 35 ohm speaker. Input 10mV into 2kΩ. Operates from 9V d.c.

All parts and instructions come to **39/6** Ready built and tested **45/-**

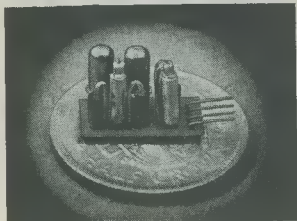

SINCLAIR MICRO-AMP

Smaller than a 3d. piece!

This fantastic amplifier has a frequency response from 30 to 50,000 c/s ± 1dB and power gain of 60dB (1,000,000 times) can be used as a broadband R.F. amplifier, A.F. quality amplifier or in a F.M. transmitter. Many other applications are given in the instructions included with set of parts. **28/6**

SINCLAIR X-10 P.W.M. AMPLIFIER WITH INTEGRATED PRE-AMPLIFIER

This superb Sinclair integrated P.W.M. amplifier and pre-amp gives you all the advantages of quality and efficiency which makes these Sinclair designs so outstanding in every way, except that it has less power than the X-20, and is suited to less spacious listening conditions. Prices are particularly attractive. For 12-15V operation. Tone control system is added to choice as described in the X-10 manual.

All parts with manual come to **£5.19.6**

Ready built and tested **£6.19.6**
 Power Pack **£2.14.0**

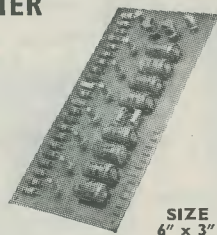

SIZE
6" x 3"

Please send me

..... NAME

..... ADDRESS

.....

for which I enclose Cash/Cheque/Money Order
 value £.....s.....d.

Guarantee

Should you not be completely satisfied with your purchase when you receive it from us, your money will be refunded in full and at once without question. Please quote R.C.9 should you prefer to write your order instead of cutting out this coupon.

IMPROVED STANDARDS of Accuracy and Reliability!

Modern styling in light grey with legible black engraving.

Constructed to withstand adverse climatic conditions.

Ever ready case including leads, prods and clips. Improved internal assemblies.

Re-styled scale plate for easy rapid reading. 2 basic scales each 2.5 inches in length.

New standards of accuracy using an individually calibrated scale plate: d.c. ranges 2.25% of full scale deflection. a.c. ranges 2.75% of full scale deflection.

Available accessories include a 2,500V d.c. multiplier and 5, 10 and 25A shunts for d.c. current measurement.

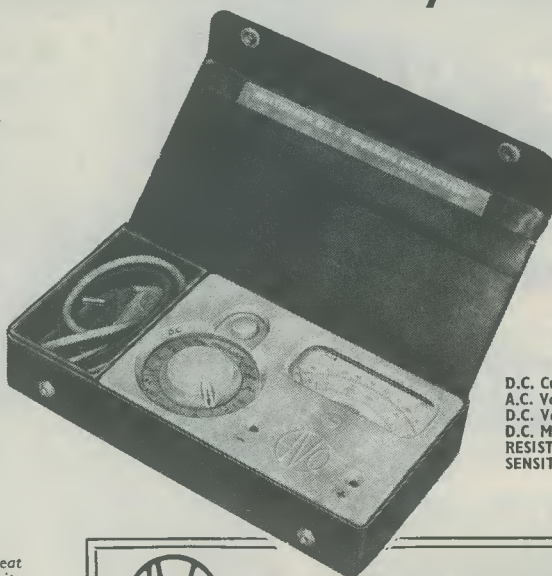

The Mk. 4 MULTIMINOR, the latest version of this famous Avo instrument, supersedes all previous models. It is styled on modern lines, with new high standards of accuracy, improved internal assemblies, and incorporating panclimatic properties.

The instrument is supplied in an attractive black carrying case, which also houses a pair of leads with interchangeable prods and clips, and an instruction booklet. It is packed in an attractive display carton. Robust real leather cases are available, if required, in two sizes, one to take the instrument with leads, clips and prods, and the other to house these and also a high voltage multiplier and a d.c. shunt.

D.C. Current: 100 μ A f.s.d. — 1A f.s.d. in 5 ranges.
 A.C. Voltage: 10V f.s.d. — 1,000 f.s.d. in 5 ranges.
 D.C. Voltage: 2.5V f.s.d. — 1,000 f.s.d. in 6 ranges.
 D.C. Millivolt range: 0 — 100mV f.s.d.
 RESISTANCE: 0-2M Ω in 2 ranges, using 1.5V cell.
 SENSITIVITY: 10,000 Ω /V on d.c. Voltage ranges.
 1,000 Ω /V on a.c. Voltage ranges.

★ For full details of this great pocket size instrument, write for descriptive leaflet.



MULTIMINOR Mk 4

AVO LTD

AVOCET HOUSE, 92-96 VAUXHALL BRIDGE ROAD, LONDON, SW1

Telephone: VICTORIA 3404



MM 17

THE MODERN BOOK CO

The Radio Amateur's V.H.F. Manual. By A.R.R.L. 18s. Postage 1s. 6d.

Basic Theory and Application of Transistors. U.S. ARMY. 10s. Postage 1s.

An Electronic Organ for the Home Constructor. By A. Douglas. 20s. Postage 1s.

The Amateur Radio Handbook. An R.S.G.B. Pub. 34s. Postage 2s. 6d.

A Beginner's Guide to Radio. Pub.: Newnes. 8s. 6d. Postage 9d.

Radio Control for Models. By F. C. Judd. 15s. Postage 1s.

Transistor Substitution Handbook. 12s. 6d. Postage 1s.

Tube Substitution Handbook. Pub.: Foulsham-Sams. 12s. 6d. Postage 1s.

Transistor Radios Circuitry and Servicing. By Mullard. 5s. Postage 6d.

How To Listen To The World, 1965-66. 20s. Postage 1s.

Advanced Radio Control. By E. L. Safford. 25s. Postage 1s.

Transistor Electronic Organs for the Amateur. By A. Douglas and S. Astley. 18s. Postage 1s.

Guide to Broadcasting Stations. Compiled by "W.W." 5s. Postage 6d.

Radio and Television Test Instruments. By G. J. King. 25s. Postage 1s. 6d.

Television Servicing Handbook. By G. J. King. 35s. Postage 1s. 6d.

ABC's of Hi-Fi and Stereo. By H. Fantel. 16s. Postage 1s.

Amateur Radio Mobile Handbook. By C. Caringella. 24s. Postage 1s.

Organ Builders Manual, 6th Ed. Pub.: Artisan Organs. 35s. Postage 2s.

Complete Catalogue 1s.

We have the Finest Selection of English and American Radio Books in the Country

19-21 PRAED STREET (Dept RC) LONDON W2

Telephone PADdington 4185

6 VALVE AM/FM TUNER UNIT

Med. and VHF 190m-550m, 86 Mc/s-103 Mc/s, 6 valves and metal rectifier. Self-contained power unit, A.C. 200/250V operation. Magic-eye indicator, 3 push-button controls, on/off, Med., VHF. Diodes and high output sockets with gain control. Illuminated 2-colour perspex dial $1\frac{1}{2}'' \times 4''$, chassis size $1\frac{1}{2}'' \times 4'' \times 5\frac{1}{2}''$. A recommended Fidelity Unit for use with Mullard "3-3" or "5-10" Amplifiers. Available only at present as built-up units, aligned and tested ready for use.

Bargain Price £12.10.0. Carr. 5/-. This popular unit will be available in kit form within the next few weeks. Circuit and constr's details, 2/6.



7 VALVE AM/FM RADIOGRAM CHASSIS

New 1965 Model Now Available.

Three Waveband & Switched Gram positions. Med. 200-550m. Long 1,000-2,000m. VHF/FM 88-95 Mc/s. Phillips Continental Tuning insert with permeability tuning on FM & combined AM/FM IF transformers. 460 kc/s and 10.7 Mc/s. Dust core tuning all coils. Latest circuitry including AVC & Neg. Feedback, 3 watt output. Sensitivity and reproduction of a very high standard. Chassis size $1\frac{1}{2}'' \times 6\frac{1}{2}'' \times 7\frac{1}{2}''$. Edge illuminated glass dial $1\frac{1}{2}'' \times 3\frac{1}{2}''$. Vert. pointer Horiz. station names. Gold on brown background. A.C. 200/250V operation. Magic-eye tuning. Circuit diag. now available.

Comp. with Tape, O/P socket, ext. spk'r & P/U sockets and indoor F.M. aerial, and 4 knobs—walnut or ivory to choice. 3Ω P.M. Speaker only required. Recommended Quality Speakers 10" R.R. 27/6. $13\frac{1}{2}'' \times 8''$ E.M.I. Fidelity, 37/6. 12" R.A. with conc. Tweeter, 42/6. Carr. 2/6.

Valves ECC85, ECH81 EF89, EABC80, EL84 EM81, EZ80



Aligned and tested ready for use. **£13.19.6** Carr. & Ins. 7/6.

Jack Plugs. Standard $2\frac{1}{2}''$ Igranite Type, 2/6. Screened Ditto, 3/3. Miniature scr. $1\frac{1}{2}''$, 2/3. Sub-min. 1/3. **Jack Sockets.** Open Igranite Moulded Type, 3/6. Closed Ditto, 4/-. Miniature Closed Type, 1/6. Sub-min. 1/6. ditto, 1/6. **Jack Sockets, 3/6.** Stereo Jack Plugs, 3/6. **Phono Plugs, 9d.** Phono Sockets (open), 9d. Ditto (closed), 1/-. Twin Phono Sockets (open), 1/3.

Grundig Continental. 3 p. or 5 p. plug, 3/6. Sockets, 1/6. **Soldering Irons.** Mains 200/220V or 230/250V. Solon 25W Inst., 22/6. Spare Elements, 5/6. Bits, 1/3. 65W, 27/6, etc. **Alumin. Chassis.** 18g. Plain Un-drilled, folded 4 sides, 2" deep, 6" x 4", 4/6, 8" x 6", 5/9, 10" x 7", 6/9, 12" x 6", 7/6, 12" x 8", 8/-. etc. **Alumin. Sheet.** 18g. 6" x 6", 1/-. 6" x 9", 1/6, 6" x 12", 2/-. 12" x 12", 4/6, etc.

RECORDING TAPE

Famous American Columbia (CBS) Premier quality tape at NEW REDUCED PRICES. A genuine recommended Quality Tape—TRY IT BRAND new, boxed and fully guaranteed. Fitted with leader and stop foils.

Standard Double Play Long Play SPECIAL OFFER. 3" Message tape 150', 3/9; 3" L.P. 5" 600' 13/-, 1,200' 31/6 900' 17/6 2,200' 37/6 2,400' 19/6 2,225' 4/9; 3" R.P. 300', 6/6. 7" 1,200' 21/-, 2,400' 47/6, 1,800' 28/6. P. & P. per reel 6d.

Post & Package per reel, 1/- plus 6d. each for additional reels. **TAPE REELS.** Mfrs. surplus 7", 2/3; 5 1/2", 2/-; 5", 2/-; 3", 1/3; Plastic spool containers, 5", 1/9; 5 1/2", 2/-; 7", 2/3.

New Boxed	VALVES	Reduced	Bargain Prices
IT4	3/6	EF80	7/6
IR5	6/-	EF86	8/6
IS5	6/-	EL33	12/6
3V4	7/-	EL34	12/6
354	7/-	EL84	7/-
ECC81	7/-	EY51	9/-
ECC82	7/-	EY86	9/-
ECC83	7/-	EY20	7/-
ECL80	9/-	EZ81	7/-
ECL82	10/-	GZ32	9/6
ECL86	10/6	PCC84	8/-

Electrolytics All Types New Stock	
TUBULAR	CAN TYPES
25/50V	1/9
50/12V	1/9
50/50V	2/-
100/25V	2/-
PL36 10/6	2/3
8/450V	2/3
16+16/450V	5/6
32+32/450V	6/6
100/25V	3/9
Erskin Multicore	50/40, 4d.

DE LUXE R/PLAYER KIT

Incorporating 4 Speed Garrard Auto-Slim unit and Mullard latest 3 watt printed circuit amplifier (ECL 86 and EZ 80), volume, bass and treble controls, with 8" x 5" 10,000 line speaker. Superb quality reproduction.

Contemporary styled two-tone cabinet, charcoal grey and off-white with matching blue relief. Size: $17\frac{1}{2}'' \times 16'' \times 8''$.

COMPLETE KIT £13.19.6 Carr. & ins. 10/-

Illuminated Perspex escutcheon, 7/6 extra. Ready wired 30/- extra. 4 Contemporary legs (6" or 13") 12/6 per set. Catalogue & construction details 2/6 (free with kit)

STANDARD RECORD PLAYER KIT

Using BSR UA14 Unit, complete kit £11.10.0, carr. 7/6. Ready wired amplifier, 7" x 4" quality Speaker and O/P trans., £3.19.6, carr. 2/6. BSR UA14 Unit, £6.10.0, carr. & ins. 5/-. Rexine covered cabinet in two-tone maroon and cream, size $15\frac{1}{2}'' \times 14\frac{1}{2}'' \times 8\frac{1}{2}''$ with all accessories plus uncut record player mounting board $14'' \times 13''$, 59/6, carr. & ins. 5/-.

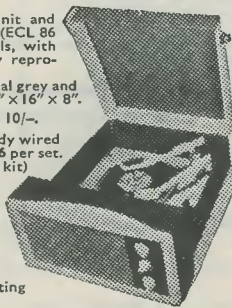

Condensers—S/Mica all values 2pF to 1,000pF 6d. Ditto Ceramic 9d. each, .005, .01 and .1, etc., 1/-. Paper Tubular 450V .001 mfd. to .01 mfd and 1/340V 9d., .02-1 mfd 1/-, .25 mfd 1/6, 5 mfd 1/9.

Speakers P.M.—2" Plessey 75 ohms, 15/6. 2 1/2" Continental 8 ohms, 13/6. 7" x 4" Plessey 35 ohm, 23/6. **Ear Plug Phones**—Min. Continental type, 3ft. lead, jack plug and socket. High Imp. 8/-, Low Imp., 7/6. High sensitivity M/coil 8-10 ohms, 12/6.

26 1/2 gns TAPE RECORDER for ONLY £19.10.0 carr. 10/-

Bargain of the Year Offer—Cancel Export Contractors

Famous manufacturer's brand new unused and factory tested 2-speed, 3 1/2 and 7 1/2 i.p.s., twin track tape recorders. 3 Watt output. Tape position Rev-counter, fast forward and rewind, takes 7" reels, mike and gram input. Straight through amplifier facilities. Output sockets for ext. speaker, monitor or external amplifier. Super-imposed switching, magic eye recording level and mains neon indicators, Volume and tone controls, 7" x 4" speaker. Attractively styled cabinet, with detachable lid, mike and reel storage facilities. AC 200/250 volts operation. Complete with crystal mike, tape, spare reel and screen lead, etc.



Volume Controls—5K-2 Megohms, 3" Spindles Morganite Midget Type. $1\frac{1}{2}''$ diam. Guar. 1 year. LOG or LIT ratios less Sw. 3/-. D.P. Sw. 4/6. Twin Stereo less Sw. 6/6. D.P. Sw. 9/6 (100 kc. to 2 Meg. only). 1/2 Meg. VOL Controls D.P. Sw. 1/2" flatted spindle. Famous Mfrs. 4 for 10/- post free.

ENAMELLED COPPER WIRE—1 1/2 lb reels, 14g-20g, 3/-; 22g-28g, 3/6; 36g-38g, 4/9; 39-40g, 5/-, etc.

TINNED COPPER WIRE—14-22g. 3/- 1/2 lb.

PVC CONNECTING WIRE—10 colours (for chassis wiring, etc.)—Single or stranded conductor, per yd., 2d. Sleeving, 1mm, and 2mm, 2d. yd., etc.

KNOB—Modern Continental types: Brown or Ivory with Gold Ring, 1" dia., 9d. each; 1 1/2", 1/- each; Brown or Ivory with Gold Centre, 1" dia., 10d. each; 1 1/2", 1/3 each. LARGE SELECTION AVAILABLE.

TRANSISTOR COMPONENTS
Midget I.F.'s—465 kc/s 1/2" diam. 5/6
Osc. Coil—1/2" diam. M/W. 5/3
Osc. coil M. & L.W. 5/9
Midget Driver Trans. 3.5:1 6/9
Ditto O/P Push-pull 3 ohms 1/9

COAX 80 OHM CABLE

High grade low loss Cellular air spaced Polythene—1/2" diameter. Stranded conc. Famous mfrs. Now only 6d. per yard.

Bargain Prices—Special lengths:
20 yds. 9/- P. & P. 1/6.
40 yds. 17/6 P. & P. 2/-.
60 yds. 25/- P. & P. 3/-.
Coax Plugs 1/- Sockets 1/-
Couplers 1/3. Outlet Boxes 4/6

Close Tol. S/Micas—10% 5pF-500pF 8d. 600-5,000pF 1/- 1% 2pF-100pF 9d. 100pF-500pF 11d. 575pF-5,000pF 1/6. **Resistors**—Full Range 10 ohms-10 megohms 20% 1/2 and 1/2 W 3d., ditto 10% 4d. 1/2 W 5d. (Midget type modern rating) 1W 6d., 2W 9d., Hi-Stab 5% 1/2 W 100 ohms 1 megohm 6d. Other values 9d. 1% 1/2 W 1/6. **W/W Resistors** 25 ohms to 10K 5W 1/3, 10W 1/6, 15W 2/-. **Pre-set T/V Pots.** W/W 25 ohms—50K 3/-. 50K-2 Meg. (Carbon) 3/-. **Speaker Fret**—Expanded gilt anodised metal 1/2" x 1/2" diamond mesh, 4/6 sq. ft., multiples of 6" cut. Max. size, 4ft. x 3ft. 47/6. Carr. extra. Ditto, finer mesh, 4/6 sq. ft. Multiples 12" only, max size 3ft x 2ft. 27/6. Plus Carr.

TYGAN FRET (contemp. pat.) 12" x 12" 2/-, 12" x 18" 3/-, 12" x 24" 4/-, 18" x 18" 4/6, etc. **BONDACOUST** Speaker Cabinet Acoustic Wadding, superior grade, 1" thick, 18" wide, any length cut 2/3 per ft, 6/- per yd.

Elect. Condensers—Midget Type 15V 1mfd-50mfd, ea. 1/9. 100mfd. 2/-.

Ferrite Aerial—M. & L. W. with car aerial coupling coil, 9/3.

Condensers—150V. wkg. .01 mfd. to .04 mfd., 9d. .05 mfd., 1 mfd., 1/-, .25 mfd., 1/3. 5 mfd., 1/6, etc.

Tuning Condensers. J.B. "00" 208 + 176pF, 8/6. Ditto with trimmers, 9/6. 365pF single, 7/6. Sub-min. 3" DILEMIN 100pF, 300pF, 500pF, 7/-.

Midget Vol. Control with edge control knob, 5kΩ with switch, 4/9, ditto less switch, 3/9.

JASON FM TUNER UNITS

Designer-approved kit of parts:
FMT1, 5 gns. 4 valves, 20/-.
FMT2, £7.10.0. 5 valves, 35/-.
JTV MERCURY 10 gns.
3 valves, 22/6.
JTV2 £13.19.6, 4 valves, 28/6.
NEW JASON FM HAND-BOOK, 2/6, 48 hr. Alignment Service 7/6. P. & P. 2/6.

MULLARD "3-3" & "5-10" HI-FI AMPLIFIERS 3 OHM & 15 OHM OUTPUT

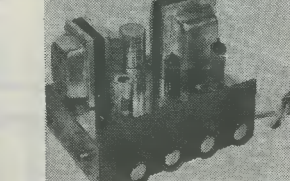

"3-3" Amp. 3-valve, 3 watt, Hi-Fi quality at reasonable cost. Bass Boost and Treble controls, quality sectional output transformer, 40 c/s-25 kc/s ± 1dB. 100mV for 3W, less than 1% distortion. Bronze escutcheon panel.

Complete Kit only £6.19.6. Carr. 5/-. Wired and tested £8.10.0

MULLARD "5-10" AMPLIFIER—5 valves 10W, 3 and 15 ohms output.

Mullard's famous circuit with heavy duty ultra-linear quality output tfr. Basic amplifier kit price £9.19.6. Carr. 7/6. Ready built $1\frac{1}{2}''$ gns.

2-VALVE PRE-AMP. UNIT

Based on Mullard's famous 2-valve (2 x EF86) circuit with full equalisation with volume, bass, treble, and 3-position selector switch. Size 9" x 6" x 2 1/2". Ready built, wired and tested, £7.19.6. Carr. 3/6.



Send for detailed bargain lists, 3d. stamp. We manufacture all types Radio Mains Transf. Chokes, Quality O/P Trans., etc. Enquiries invited for Specials, Prototypes for small production runs. Quotation by return.

70 RADIO COMPONENT SPECIALISTS

RADIO STOCK ROAD, Thornton Heath, Surrey T.O. 2188. Hours: 9 a.m.-6 m., 1 p.m. Wed. Terms C.W.O. or C.O.D. Post and Packing up to 1/2 lb. 9d., 1 lb. 1/3, 3 lb. 2/3, 5 lb. 2/9, 8 lb. 3/6.

HOME RADIO (MITCHAM) LTD

AN INTERESTING PAGE

from the latest HOME RADIO CATALOGUE

This page, taken from the Constructional Kits section of our catalogue, shows three of the well-known "Codar" range of S.W. Kits, of which we are stockists.

You may not be particularly interested in S.W. Kits, but if you are keen on any aspect of electronics you will certainly find much to interest you on the other 205 pages. There are in fact over 5,800 items listed, indexed and priced. Over 900 of them are illustrated and we have all but about 30 of them actually in stock.

Everyone who buys our catalogue also receives the following, free of charge:

1. Additional price supplements when necessary, to keep the catalogue up-to-date in prices.
2. A list of the latest equipment from America—such as solar drive motors which can be driven by the sun's rays. (We stock these exciting new motors.)
3. A list of our latest bargains.

The Home Radio Components Catalogue costs 7/6 plus 1/6 postage and packing, and every copy contains 5 coupons each worth 1/- when used as directed. Don't delay—send off your cheque or P.O. for 9/- right away.

HOME RADIO (MITCHAM) LTD CONSTRUCTIONAL KITS

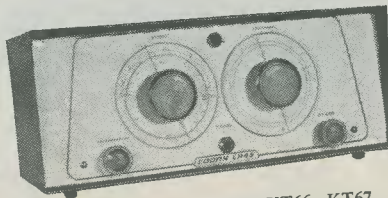

KT66 KT67

- KT66. CR45 All-band Receiver**
- Covers 150 kc/s–30 Mc/s
 - Separate electrical bandspread
 - Low-loss Polystyrene plug-in coils
 - 3 ball-bearing Vernier drives
 - Power output 3½ watts
 - Valves ECC81, EL84, EZ80
 - For A.C. Mains 200–250V.

KT67. As KT66 but ready built.
Price £10. 0. 0.
Ready built £12. 0. 0.

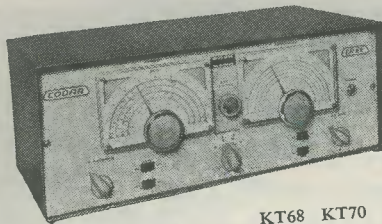

KT68 KT70

- KT68. CR66 Communication Receiver**
- For A.C. Mains 200–250V. 540 kc/s–30 Mc/s in four ranges.
Valve line up: ECH81, EBF89, ECC81, EL84, EZ80, EM84.

KT69. As KT68 but with "S" meter.
KT70. As KT68 but ready built.
KT71. As KT69 but ready built.
KT72. Matching speaker for use with the above kits.
Price (KT68) .. £19.15. 0.
Ready built (KT70) £23. 0. 0.

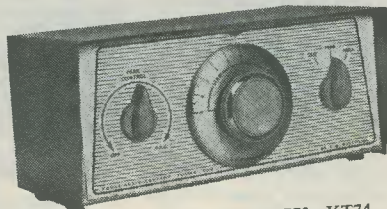

KT73 KT74

- KT 73. PR30. R.F. Pre-selector**
- Frequency range 1.5–30 Mc/s.
Band 1, 30–11.5 Mc.
Band 2, 11.5–4.2 Mc.
Band 3, 4.2–1.5 Mc.

External power required: 180–250 at 12mA, 6–3V at 0.3A.
KT74. As KT73 but self-powered.
Price £3.19. 6.
Self-powered £7. 4. 0.

Please write your Name and Address in block capitals

Name

Address

Home Radio Ltd., Dept. RC, 187 London Road, Mitcham, Surrey

THE Radio Constructor



Incorporating THE RADIO AMATEUR

SEPTEMBER 1965

Vol. 19, No. 2
Published Monthly
(1st of month)

*Editorial and
Advertising Offices*

57 MAIDA VALE LONDON W9

Telephone
CUNningham 6141

Telegrams
Databux, London

First Published
1947

Electronic Counting with Dekatrons, Part 1, <i>by G. W. Pilliner, B.Sc.</i>	82
Recent Publications	88
New Life for Mains-Battery Portables (Suggested Circuit No. 178), <i>by G. A. French</i>	89
Can Anyone Help?	92
News and Comment	93
A Quality Multimeter, Part 1, <i>by W. Kemp</i>	94
Simple Transistor Tester, <i>by B. Andrews</i>	100
In Your Workshop	101
Beginner's A.F./R.F. Signal Tracer, Part 2, <i>by P. Vernon</i>	109
The Story of the Valve, Part 1, <i>by C. H. Gardner</i>	112
Measuring Oscilloscope Input Voltage, <i>by H. T. Kitchen</i>	114
Club Events	117
Understanding Radio, <i>by W. G. Morley</i>	118
Cold Cathode Trigger Tubes and their Uses, <i>by J. B. Dance, M.Sc.</i>	124
Power Amplifier for Portable Radio, <i>by J. R. Brooks</i>	127
Transistor Beat Frequency Audio Oscillator, <i>by D. Bollen</i>	130
Radio Topics, <i>by Recorder</i>	133

© Data Publications Ltd., 1965. Contents may only be reproduced after obtaining prior permission from the Editor. Short abstracts or references are allowable provided acknowledgement of source is given.

Annual Subscription 33s. (U.S.A. and Canada \$5) including postage. Remittances should be made payable to "Data Publications Ltd". Overseas readers please pay by cheque or International Money Order.

Published in Great Britain by the Proprietors and Publishers Data Publications Ltd. 57 Maida Vale London W9
Printed by A. Quick & Co. (Printers) Ltd. Oxford Road Clacton-on-Sea England

ELECTRONIC COUNTING with DEKATRONS

Part I

By G. W. Pilliner, B.Sc.

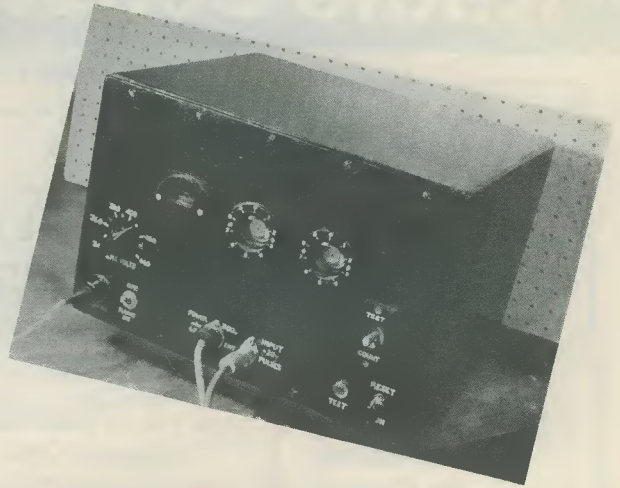

Electronic counters offer a considerable range of applications in industry, in the laboratory and in the field of experiment. This two-part series discusses an electronic counter having a maximum speed of 800 pulses per second which may be entirely home-constructed. The design employs two dekatrons followed by a mechanical register (or counter), and the circuit can be extended to include further dekatrons, if desired

The first part of the series is devoted to the operation and construction of the counter chassis proper, whilst next month's concluding instalment will describe the stabilised power pack, the complete assembly, fault-finding and modifications

IN THE LAST THIRTY YEARS THE DEVELOPMENT OF work with radioactive substances and computers has resulted in the widespread use of high speed electronic counting equipment. Originally such counters were based on the bistable flip-flop circuit and operated meters or simple neon indicators. Now, however, a number of new electronic devices are available which have made enormous simplifications in electronic counting techniques. The most familiar of these is the dekatron, and the purpose of these articles is to describe the construction of an electronic counter using these tubes. The equipment to be described was originally constructed to be used with a geiger tube for work with radioactive materials, but it can equally well be used for the measurement of low frequencies, as a timer, or for counting anything which can be represented by electric pulses. This counter has a maximum operating speed of about 800 pulses per second, although speeds up to 20,000 pulses per second can be obtained with certain types of dekatron and suitable circuitry.

The author claims no originality for the dekatron circuits, and is glad to acknowledge his gratitude to Ericsson Telephones Ltd. for allowing him to make full use of their circuits and other data in this article.

The Principle of the Dekatron

The simple dekatron is a tube containing neon gas, fitted with a central anode, ten cathodes, and twenty subsidiary cathodes called guides, arranged as shown in Fig. 1.¹ The two guides between each cathode are known as the first and second guides. All the first guides are connected together, as are all the second guides. For simple counting, nine of the cathodes are also connected together, but the tenth is brought to a separate pin on the base.

In any gas discharge tube, a discharge will strike initially across the electrodes with the greatest potential difference between them, because this is where the field is strongest. In a dekatron tube the discharge will occur between the anode and any one of the cathodes, depending on the random distribution of ions when the potential difference is applied. Once current is flowing the potential will drop to the running potential of 190 volts, the current being limited by the anode resistor R_a . (See Fig. 2.) When the gap potential is 190 volts the potential difference between the guides on either side of the cathode and the anode is only 172 volts. This is less than the

¹ A very detailed description of dekatron operation was given by J. B. Dance in "Gas Filled Counting Tubes" in *The Radio Constructor* for October 1964. Although it has now achieved general usage, the word Dekatron is really a registered trade name for gas filled counting tubes manufactured by Ericsson Telephones Ltd.—EDITOR

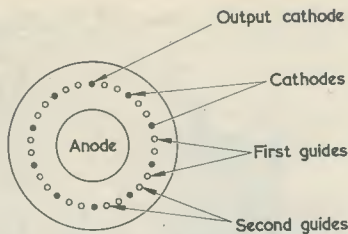

Fig. 1. Arrangement of electrodes in a dekatron as seen through the top of the tube. Cathodes are shown as filled circles and guides as open ones. They are, however, indistinguishable in an actual tube

running voltage, so the discharge is stabilised on one of the main cathodes. It cannot transfer to another main cathode because the striking voltage to these cathodes, as is characteristic of any gas diode, is considerably higher than the running voltage of 190 volts.²

If a large negative pulse is passed to the first guides, sufficient to exceed the striking voltage, the discharge will transfer to that first guide nearest to the cathode which carried the discharge. Similarly, a second pulse immediately after the first, and applied to the second guides, will cause the discharge to transfer once more to the adjacent second guide. This is usually achieved in practice with a single pulse by passing the pulse through a delay network to the second guides. Once the pulse on the second guide has decayed, the discharge transfers to the nearest cathode, which will now be the next one round in a clockwise direction. Thus each pulse moves the discharge from one cathode to the next. When the discharge reaches the output cathode, the current flowing through the output resistor R_0 causes a rise of potential of about 40 volts, giving a pulse which can be amplified to drive a second dekatron.

² For further information on the behaviour of gas diodes see "Cold Cathode Diodes And Their Uses" by J. B. Dance in *The Radio Constructor* for January 1964.

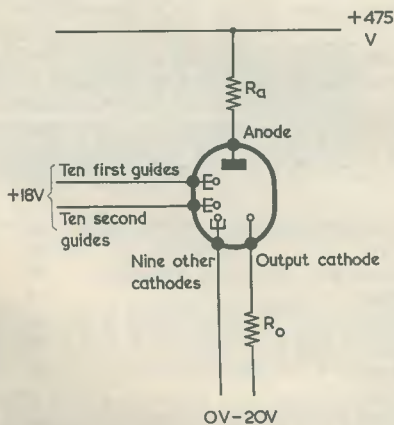
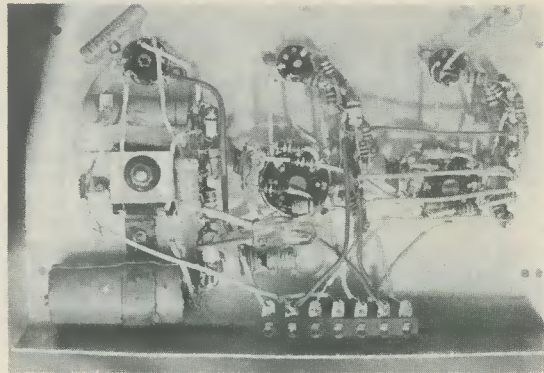

Fig. 2. Bias conditions for a simple dekatron circuit



Wiring below the chassis in the prototype

The discharge is visible through the dome of the tube. Thus the position of the discharge indicates directly the number of pulses the tube has registered.

The Practical Circuit

Fig. 3 is the circuit diagram of the counter and the operating conditions of the dekatron tube and trigger tubes are summarised in Tables I and II. The counter employs two dekatron stages followed by a monostable multivibrator trigger circuit driving a mechanical register.

The bias on the trigger of V_1 is set at 160 volts by the potential divider R_1R_2 . The auxiliary diode is connected through R_4 to the -100 volt bias line, and strikes, providing electrons for the main and trigger gaps when required. The main gap is initially non-conductive, so there is 300 volts on the anode. When a 20 volt positive pulse is passed through C_1 the trigger rises to 180 volts and strikes, causing the main gap to strike too. The anode voltage drops to 150 volts, whereupon a negative pulse of 150 volts passes through C_2 to the first guide of the dekatron. A similar pulse reaches the second guide, delayed some $60\mu S$ by the time constant of R_5C_3 . The current through V_1 is limited by the charge held on C_2 and C_3 , and by the resistors R_5 and R_6 . Once the excess charge on the capacitors has disappeared R_5 and R_6 do not pass enough current to maintain the discharge, which is then extinguished.

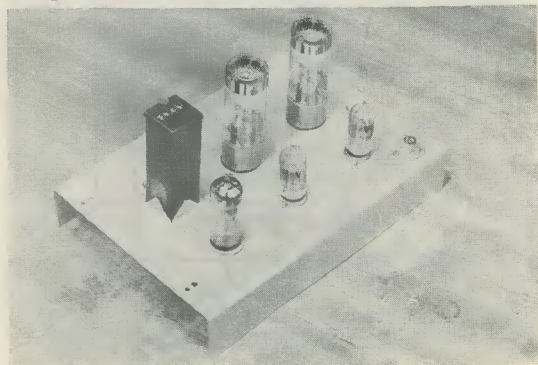

The components mounted on the counter chassis

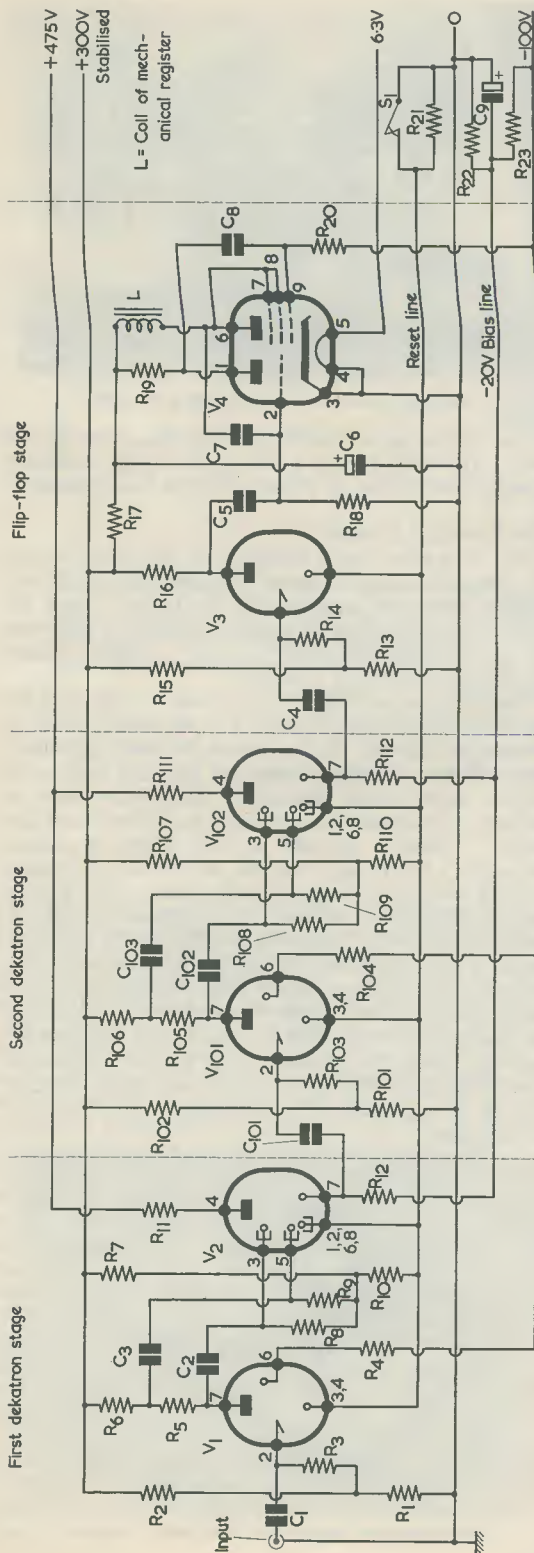

Fig. 3. Circuit diagram for the two-stage dekatron counter with mechanical register

Resistors

(All 10% 1/2 watt unless otherwise specified)

- R₁ 150kΩ 5%
- R₂ 130kΩ 5%
- R₃ 1MΩ
- R₄ 10MΩ
- R₅ 68kΩ
- R₆ 390kΩ
- R₇ 820kΩ
- R₈ 120kΩ
- R₉ 120kΩ
- R₁₀ 39kΩ
- *R₁₁ 820kΩ
- R₁₂ 150kΩ
- *R₁₃ 220kΩ
- R₁₄ 270kΩ
- *R₁₅ 270kΩ
- R₁₆ 1MΩ
- R₁₇ 6.8kΩ 2 watts
- R₁₈ 470kΩ
- R₁₉ 100kΩ
- *R₂₀ 330kΩ
- R₂₁ 150kΩ
- *R₂₂ 8.2kΩ
- R₂₃ 33kΩ
- R₁₀₁ 150kΩ 5%
- R₁₀₂ 130kΩ 5%
- *R₁₀₃ 1MΩ
- R₁₀₄ 10MΩ
- R₁₀₅ 68kΩ
- R₁₀₆ 390kΩ
- R₁₀₇ 820kΩ
- R₁₀₈ 120kΩ
- R₁₀₉ 120kΩ
- R₁₁₀ 39kΩ
- *R₁₁₁ 820kΩ
- R₁₁₂ 150kΩ

* May require adjustment on final test.

Components List
(Counter Chassis)

Capacitors

- C₁ 0.001μF, 350V wkg.
- C₂ 0.001μF, 350V wkg.
- C₃ 0.002μF, 350V wkg.
- C₄ 0.001μF, 350V wkg.
- C₅ 0.001μF, 350V wkg.
- C₆ 50μF, 350V wkg, electrolytic, with clip (Fig. 8)
- C₇ 0.01μF, 500V wkg.
- C₈ 0.1μF, 50V wkg., electrolytic
- C₉ 25μF, 50V wkg., electrolytic

Mechanical Register

Mechanical register with 2,300Ω coil.
Available from Service Trading Co.,
47-49 High Street, Kingston-on-Thames

Miscellaneous

- 1 6.3-volt dial lamp
- Aluminium for chassis and register bracket
- 4 No. 6 wood screws

Sockets

- 2 International octal valveholders
- 2 B7G valveholders
- 1 B9A valveholder
- 1 coaxial socket
- 1 dial lamp holder

Tagstrips

- 3 with 7 tags, centre tag earthed
- 1 with 6 tags, third tag earthed
- 1 with 3 tags, centre tag earthed
- 3 with 1 tag, insulated from chassis.

Note: All tagstrips are shown in Fig. 8.

Valves

- V₁, V₁₀₁ GTE 175M
- V₂, V₁₀₂ GC 10B
- V₃ GTR 120W
- V₄ ECL80

Note: The dekatrons and trigger tubes are manufactured by Ericsson Telephones Ltd., and may be purchased from them at Ericssons Telephones Ltd., Tube Division, Beeston, Notts.

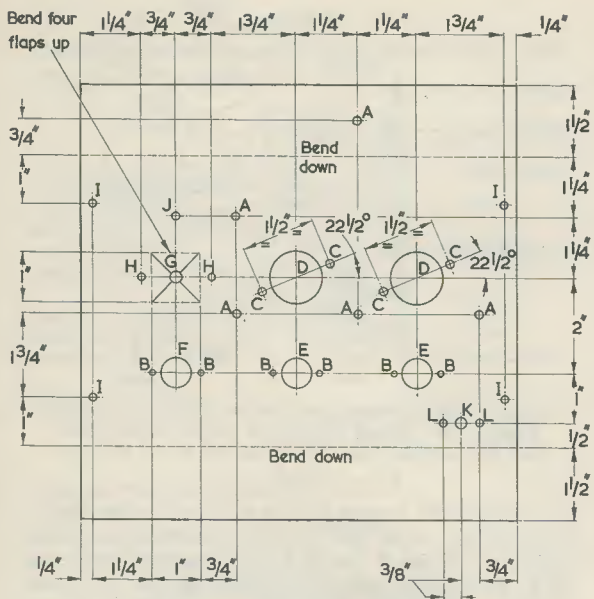

Material: 18 or 20 s.w.g. aluminium

Fig. 4. Top view of counter chassis showing cutting and drilling dimensions. The various holes are discussed in the text. The chassis is made from a piece of 18 s.w.g. aluminium measuring 9 x 9 in

TABLE I

Principal characteristics of GC 10B series of dekatron tubes

Running voltage (at 300 microamps.)	190 volts
Minimum supply voltage	350 volts
Anode current—maximum	550 microamps.
—minimum	250 microamps.
Guide bias	+18 volts
Output cathode bias	-20 volts
Pulse amplitude } (single integrated	145 volts
Pulse duration } pulse operation)	80 microsecs.
Maximum counting rate	4,000 p.p.s.
GC 10B/L and GC 10B/S are special quality versions of GC 10B.		

GC 10/4B is identical to GC 10B except that four of its cathodes are brought to separate pins on the base and may be used separately or connected to the common cathodes for normal operation.

GC 12/4B is similar to GC 10/4B but has 12 cathodes for counting in twelves.

Valve base connections—International octal base

Pin Number	GC10B	GC 10/4B
1	common cathodes	common cathodes
2	—	cathode 5
3	first guides	first guides
4	anode	anode
5	second guides	second guides
6	—	cathode 9
7	output cathode	cathode 0
8	—	cathode 3

Before the arrival of the pulse on the guides of V_2 they are held at +18 volts by the potential divider R_7R_{10} . The output cathode (unless it happens to be conducting) is at -20 volts. One of the cathodes is conducting (as will be shown by the orange glow surrounding it). The anode potential is 190 volts, and R_{11} limits the anode current to 300 μ A. The arrival of the pulse causes the discharge to transfer in a clockwise direction to the first guide, then the second guide, after which it passes to the next cathode. (If the pulse were led to the second guide first the discharge would move in the opposite direction.) When the discharge reaches the output cathode, the current through R_{12} causes the output cathode potential to rise to +20 volts, thereby passing a pulse of 40 volts through C_{101} to the trigger of V_{101} .

The second stage is identical in every way to the first. The output pulse from this stage is fed to another trigger tube, V_3 , which amplifies and reverses the phase of the pulse to operate the multivibrator. A subminiature GTR 120W has been used for V_3 . This trigger tube requires illumination to provide sufficient photoelectrons for reliable triggering, and to achieve this a small dial lamp is fitted near it. The GTE 175M could be employed in place of this tube if components of the same values as C_1 , C_2 , and R_1 to R_6 were used. The trigger tube gives a negative pulse of about 150 volts. The triode section of the ECL80 is normally conducting, whereas the pentode section is cut off by coupling its control grid to the -100 volt bias line. On receiving the pulse from the trigger tube the triode is cut off and a positive pulse of 200 volts passes to the pentode by multivibrator action. The pentode now conducts heavily, operating the mechanical counter. The pentode is strapped as a triode in order to reduce its anode impedance, thereby

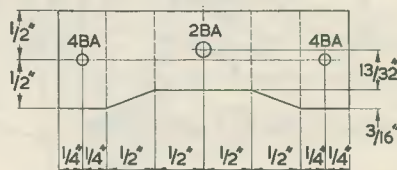

(a)

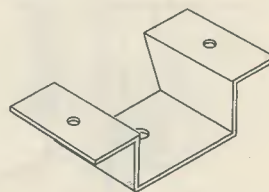

(b)

Fig. 5 (a). Dimensions for the mounting bracket for the mechanical register. Material is 18 s.w.g. aluminium

(b). The completed bracket

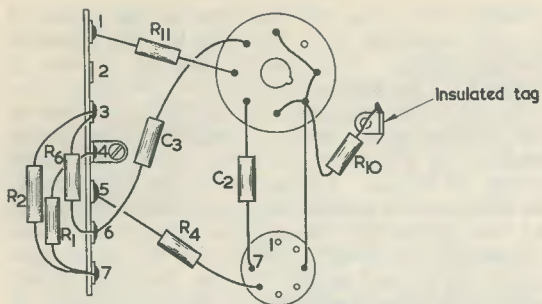

Fig. 6. The first part of the wiring of a dekatron stage. The components lie close to the chassis. The tagstrip numbers correspond to those in Fig. 8. R_1 corresponds to R_{101} in the second dekatron stage, and so on

matching it more closely to the $2,300\Omega$ load. The pulse on the pentode grid decays at a rate governed by the time constant of C_8 and R_{20} until the valve cuts off, when a pulse is fed back to the triode via C_7 , making it conduct again and become ready for the next pulse.

Constructional Details

The counter chassis is drilled and bent as shown in Fig. 4, and valve-bases and tagstrips mounted

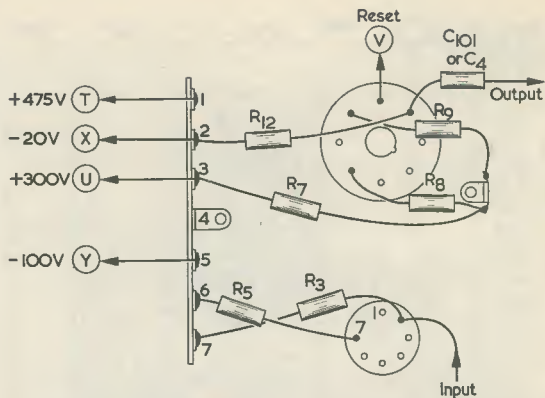

Fig. 7. The second part of the wiring of a dekatron stage. The lettered wires are those carrying h.t. and bias supplies, and they follow the routes shown in Fig. 8

to provide the layout shown in Fig. 8. In Fig. 3, holes A are 4BA and are intended for mounting tagstrips. Holes B are 6BA for mounting B7G and B9A valvebases, and are shown in the positions which apply for the Radiospares valveholders used in the prototype. If other valvebases are employed they should be mounted so that the pins take up the

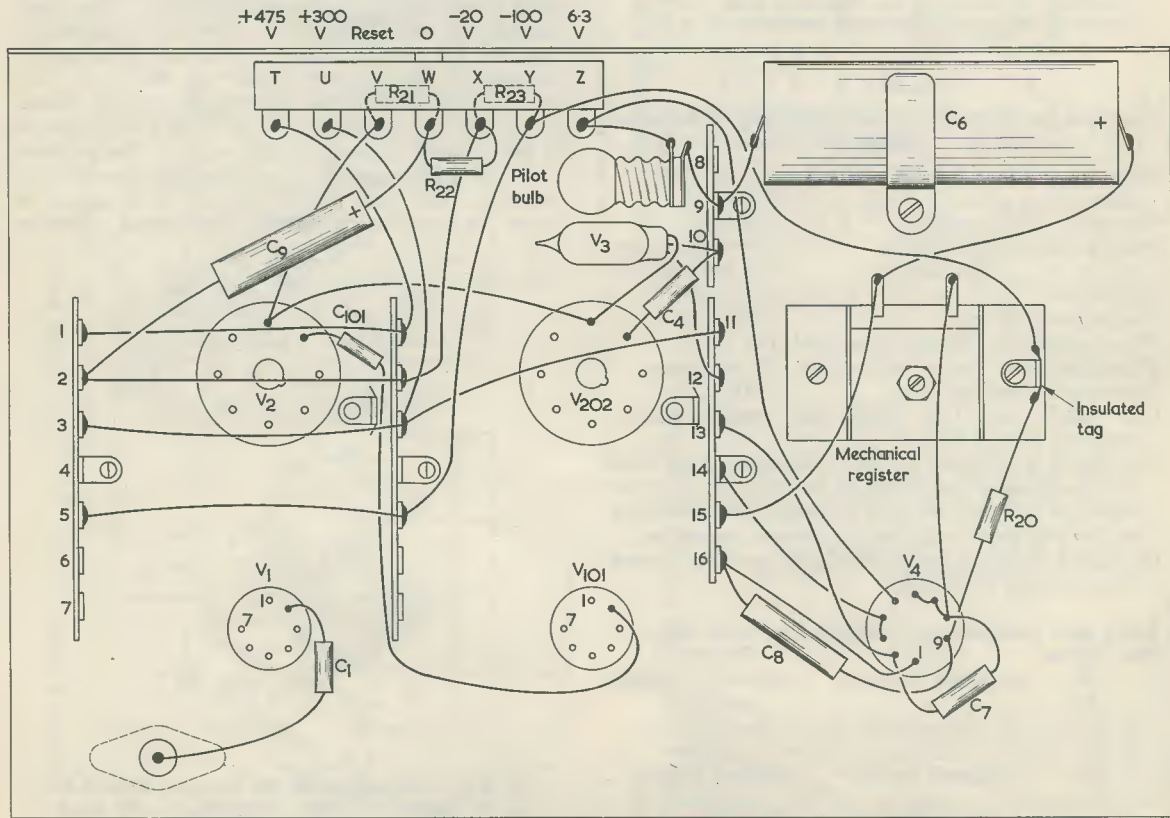

Fig. 8. Interstage wiring for the two-dekatron counter with mechanical register

TABLE II
Principal characteristics of trigger tubes GTE 175M and GTR 120W

	GTE 175M	GTR 120W
Max. anode voltage without self ignition ..	310V	310V
Max. trigger bias without self ignition ..	173V	110-160V
Anode running voltage	150V (at 2.5mA)	95-145V (at 4.5mA)
Minimum anode current	200 μ A	3mA
Deionisation time ..	500 μ secs.	3msecs.
Ionisation assisted by:	Auxiliary diode	Photoemission
Typical conditions for reliable ionisation:	Diode current 25 μ A	Illumination: 5ft-candles

Valve base connections: GTE 175M

- B7G base: Pin 1 } Trigger anode
- Pin 2 } Trigger anode
- Pin 3 } Cathode
- Pin 4 } Cathode
- Pin 5 Internally connected
- Pin 6 Auxiliary diode cathode
- Pin 7 Main anode

Connections to GTR 120W are by lead-out wires: details are given in Fig. 9 (b).

positions shown in Fig. 7. Holes C are 4BA for mounting the octal valvebases, and correspond in position to Radiospares components as used in the prototype. Whatever type of octal valveholder is used, it is essential that pin 6 be at the top (i.e. furthest away from the adjacent B7G base). This is because the output cathode electrode of the dekatron is aligned with pin 6 of the base. The output cathode corresponds to the zero position for counting and so must be positioned at the top when the chassis is mounted.

Holes D in Fig. 3 are 1 $\frac{1}{8}$ in diameter for octal valvebases, holes E are $\frac{5}{8}$ in diameter for B7G valvebases, and hole F is $\frac{3}{4}$ in diameter for the B9A valvebase. Hole G is initially a $\frac{1}{4}$ in hole, from which slots are cut as shown to give an opening measuring 1 x 1in with four lugs to support the mechanical register. See the photograph of the chassis. Holes H are 4BA and take securing bolts for the counter mounting bracket of Fig. 5. Holes I are clearance size for No. 6 woodscrews which are later used to secure the chassis in the cabinet. Hole J is 4BA, and is employed for the mounting clip for C₆ (see Fig. 8). Finally, hole K is $\frac{3}{8}$ in diameter for the coaxial socket, and holes L are 6BA for the mounting bolts for this socket.

It will also be necessary to drill a hole or holes suitable for mounting a dial lamp holder in the position shown in Fig. 8. This point is referred to in greater detail later.

The dekatrons are viewed through the top of the tube so that the chassis must be mounted to bring the domes of the tubes flush with the front of the

cabinet. In order that the front of the mechanical register is also flush with the front of the cabinet it is mounted on a small bracket. This bracket is prepared as shown in Fig. 5 and mounted to the chassis as shown in Fig. 8. The register is passed through the chassis and bolted to the bracket, ensuring that the figures on the register are the right way up. The triangular tabs on the main chassis are left in to make the register mounting more rigid, and should be a snug fit on its case. All the components shown in Fig. 8, with the exception of the pilot lamp may now be mounted in position ready for wiring.

In the wiring of the counter, tagstrips are widely used. Where a number of components are connected to a single tag with short wires it is very easy to make a bad solder joint on the lower wires. Much time and trouble will be saved later by ensuring that all joints are carefully soldered with a very hot soldering iron of the instrument type using a good quality resin cored solder, and that each component is checked after completing the joint to ensure that it is firmly held.

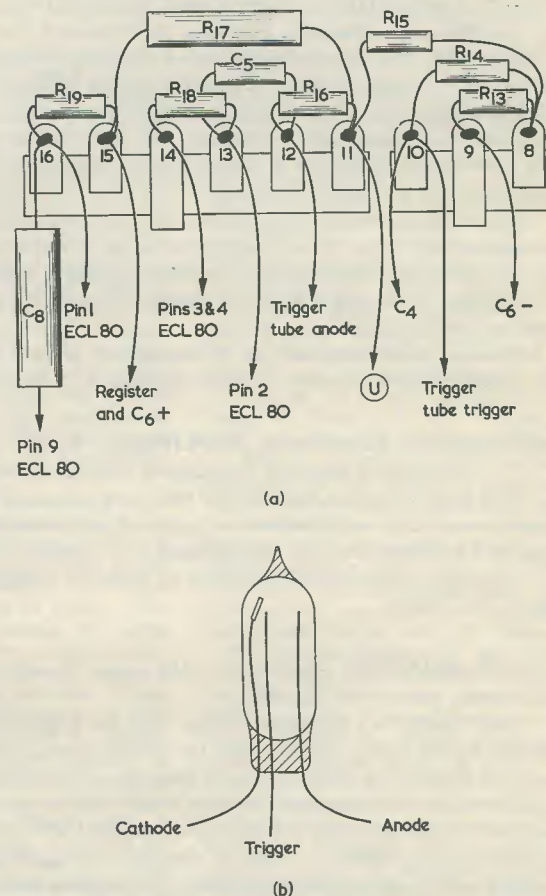

Fig. 9 (a). Tagstrip wiring for the flip-flop stage
(b). Electrode structure and connections for the GTR 120W trigger tube

The wiring of each dekatron stage is identical, and is carried out in three stages. The components lying near to the chassis are mounted first, as illustrated in Fig. 6, followed by those which cross over valveholders or other components, illustrated in Fig. 7. Finally the interstage and power supply wires are added; these are indicated by the lettered wires in Fig. 7 and illustrated in Fig. 8.

The tagstrip wiring for the multivibrator stage is illustrated in Fig. 9 (a), and the remaining connections can be seen from Fig. 8. The GTR 120W trigger tube is supported by its wires only, and is not mounted until the other wiring is complete. Care should be taken to ensure that the wires are

not bent too close to the glass seal. Fig. 9 (b) shows the electrode structure and connections for this tube. The mounting of the small lamp for illuminating the trigger tube is left to the end. The approximate position for the lamp is indicated on Fig. 8, but the design of holders for these lamps varies so much that the method of mounting must be left to the constructor.

It is important that wiring should be neat and direct. Stray capacitances due to long wires or any other reason are much more significant in pulse circuits than in normal a.c. circuits operating at similar frequencies.

(To be concluded)

Recent Publications . . .

RADIO AND AUDIO SERVICING HANDBOOK. By Gordon J. King, Assoc. I.E.R.E., M.I.P.R.E., M.T.S. 256 pages, 6 x 9in. Published by Odhams Books Limited. Price 25s.

Gordon J. King is well-known for his activities in the allied fields of technical journalism and electronic equipment design and manufacture, and it is a pleasure to the reviewer to examine his latest book. As any service engineer knows, there is a great deal more to servicing than the mere ability to understand the technical attributes of the circuits and equipment he is called upon to repair. Mr. King knows this also, and this comprehensive book always gives evidence of a working understanding of the problems which beset service engineers when clearing snags in practical equipment under practical workshop conditions.

The subjects covered include every type of a.m. and f.m. sound receiver in the various categories of mains valve circuit, battery valve circuit, battery/mains valve circuit and transistor circuit; record reproducers; turntable units and changers; and tape recorders. Where applicable, fault-tracing procedure charts are given to assist in the isolation of particular faults, and the text is liberally supported by diagrams, many of which are circuit diagrams of complete receivers or amplifiers.

This is a book which will be of considerable value to the apprentice and established service engineer and, also, to the enthusiast who maintains his own equipment or carries out occasional repairs for friends and acquaintances.

TRANSISTOR BANDPASS AMPLIFIERS. By W. Th. Hetterscheid. 338 pages, 6 x 9½in. Philips Technical Library; U.K. and Eire distributors, Cleaver-Hume Press Ltd. Price 76s.

This book, which is intended for the more advanced engineer and particularly the designer, covers the design of selective transistor amplifiers as used in the i.f. sections of radio, television and radar receivers. Single- and multi-stage amplifiers are dealt with and the approach is mathematical throughout.

Transistor Bandpass Amplifiers offers an extensive treatment which will be appreciated by those working on advanced design in this field.

AUDIO QUALITY. By G. Slot. 164 pages, 5½ x 8½in. A Philips Paperback; sole distributors Benelux, Iliffe Books Ltd. Price 13s. 6d.

Audio Quality is a refreshing change from the large number of books on hi-fi topics that have been published over the last decade or so. In this case, the author treats a purely subjective factor objectively! He asks: what is meant by "high fidelity", is absolute fidelity possible, and should we like it if we could get it?

However, the book is not intended to carry out an argument. Instead it is packed with facts ranging from apparent loudness to reverberation, and these are presented with shrewd observation and interpretation backed by the enquiring approach of the engineer. There is, also, an engaging personal style, and the text is interspersed with many touches of humour presented in dead-pan manner. "It has been reasoned that as high fidelity installations often are too expensive for young people, and old people cannot hear high frequencies anyhow, then it will not be necessary to bother about the top treble response of such installations."

Anyone interested in high fidelity reproduction will find this book of value and interest.

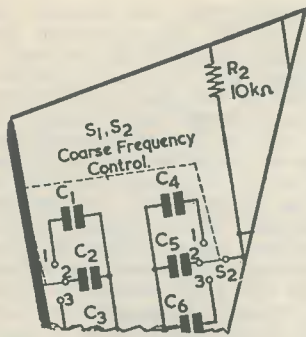

New Life for Mains-Battery Portables

SUGGESTED CIRCUIT No. 178

By G. A. FRENCH

THE ADVENT OF THE TRANSISTOR portable radio has, because of its low battery running costs, made the earlier valve portable receiver virtually obsolete. In consequence, valve portable receivers tend nowadays to be relegated to the store-room or to be otherwise disposed of. However, quite a number of the valve portables which were popular some years ago are of the mains-battery type, being capable of operation from the mains as well as from internal batteries. Whilst these sets are unattractive for battery use, they are still capable of giving excellent results when run from the mains, and they can be employed as mains-only receivers in which there is no need to have batteries fitted. As such they can be more than adequate for bedside use, as a "second set" or, indeed, for all normal domestic listening.

Unfortunately, the mains-derived filament supply circuit employed in mains-battery receivers employs components which are liable to offer reduced performance with age. Should one of these components eventually fail, causing the receiver to become unserviceable when operated from the mains, there is a tendency to look upon the set (already unattractive as a battery portable) as though it were finally "worn out", and it becomes relegated, like its battery-only counterpart, to the attic or store-room.

In this article the writer will first briefly describe the mains filament supply circuitry of conventional mains-battery portables intended for medium and long wave reception, and will then discuss the components which may cause failure whilst operating from the mains. The provision of a

modified filament circuit for mains operation will finally be described, the latter forming this month's "Suggested Circuit". The modified circuit may be used with a chain of 25mA valves (such as the DK96, DF96, DAF96 and DL96 line-up) and it overcomes many of the filament supply problems inherent in the mains-battery type of receiver. It must be emphasised that the circuit modifications require some basic experimenting and design work, and that it would be advisable to have the service sheet for the receiver available in order that its circuit and component values may be ascertained. *It must also be pointed out that it is very easy to accidentally burn out the filaments of 25mA valves, and that the modification described later in this article should not be attempted unless the constructor fully understands the principles involved and feels competent to carry out the changes required.*

Mains-Battery Receivers

The conventional type of mains-battery receiver employs four valves in a superhet circuit, with their filaments connected in series. The nominal filament voltage for three of the valves (the frequency-changer, i.f. amplifier and diode-a.f. pentode) is 1.4, whilst that for the fourth valve (the output valve) is 2.8. The output valve has a centre-tapped filament which enables it to operate also at 1.4 volts in a battery-only circuit. A typical filament chain in the 25mA range is shown in Fig. 1, but it should be mentioned that the order in which the valves appear in the chain will differ according to receiver design. It is usual to have fixed resistors across some of the filaments in the chain, but these are not shown in

Fig. 1, as their position varies in different receivers. Such resistors are fitted to bypass the anode and screen-grid currents of valves higher up in the chain, as these currents could otherwise flow through the filaments concerned and, thereby, over-run them.* It is conventional practice, also, to have one or more decoupling capacitors between chassis and the junctions of filaments, these being either electrolytic components with high values to provide a.f. decoupling, or paper or ceramic components of around 0.1μF to provide r.f. and i.f. decoupling. These additional components do not affect the present discussion, and the supply requirements of the filament chain are that 7 volts be applied across it, whereupon a current of 25mA will flow. The 7 volts is, of course, given by the sum of three 1.4 volt filaments and one 2.8 volt filament. When, in Fig. 1, the mains-battery switch S1 is set to the "Battery" position, the filament chain is applied to the terminals of a 7.5 volt battery (which, when new, offers a somewhat higher voltage than the 7 volts required). At the same time, the receiver h.t. circuits are connected to the terminals of a 90 volt battery.

For mains operation, one side of the mains supply connects direct to chassis. The other side of the mains supply is then applied, via series resistor R5, which is shown with the typical value of 470Ω in Fig. 1, to a half-wave selenium metal rectifier. A rectified voltage appears across reservoir capacitor C2 which normally has a value of around 40μF. A series of voltage dropping resistors then follows,

* The function of bypass resistors in filament chains was discussed in detail in "In Your Workshop" in the March 1965 issue—Editor.

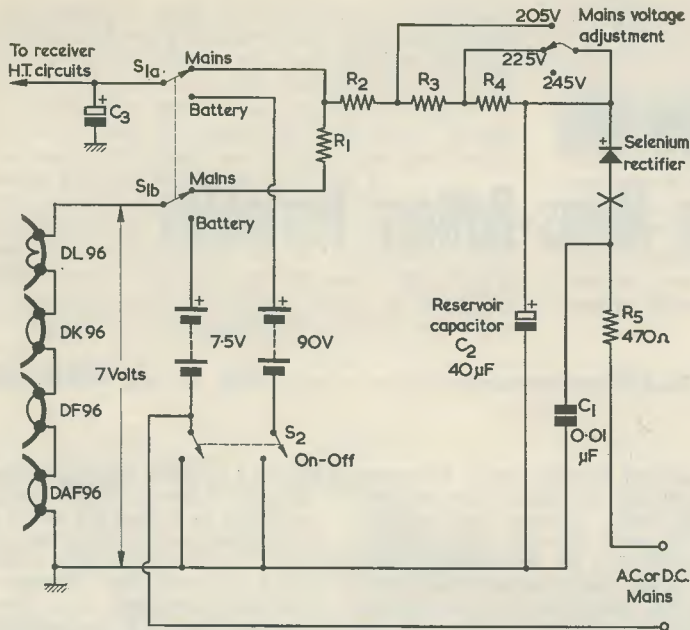

Fig. 1. The basic h.t. and filament supply circuits of a typical mains-battery receiver. The nominal voltage rating for the four filaments is 7 volts, as shown. Capacitor C_1 is an anti-mains modulation component, whilst C_3 is an h.t. smoothing and bypass capacitor. It is assumed that the receiver has a mechanical interlock which prevents S_1 being switched to "Battery" unless, for instance, the mains plug is inserted into a suitable receptacle on the receiver cabinet. Of the valves, the DAF96 is the diode-i.f. pentode, the DF96 the i.f. pentode, the DK96 the frequency-changer, and the DL96 the output pentode

an h.t. voltage of slightly less than 90 volts being drawn off at the junction of R_2 and R_1 . The final dropping resistor, R_1 , allows 25mA to flow to the filament chain via the appropriate contact of the mains-battery switch. A simple adjustment for mains voltage will also be provided, and this usually takes up the form shown in Fig. 1, in which some of the dropping resistors are short-circuited for lower voltage mains supplies.

Component Failure

When a circuit such as that of Fig. 1 is in use over a number of years, it is possible for two things to happen. The first of these is that the capacitance of the reservoir capacitor gradually falls with time, and the second is that the forward resistance of the selenium rectifier gradually increases. Either of these defects will cause a reduced rectified voltage to appear across the reservoir capacitor, and the eventual result can be that this falls to so low a level that there is insufficient voltage for the valve filaments. The receiver then stops working. In the writer's

experience, the first casualty in cases of this sort is usually the oscillator section of the frequency-changer: this ceases to oscillate on one or both bands and the set becomes "dead" as a result. It has also to be remembered that there is very little filament voltage "in hand" with these receivers so far as mains supply voltages are concerned. If, for instance, circuit conditions are such that a valve filament receives its correct voltage of 1.4 with a 250 volt mains input, the filament voltage becomes 1.26 only should the mains voltage drop to 225 volts.

Should it be found that a mains-battery receiver has low filament voltage when run from the mains it is a good plan, firstly, to replace the existing reservoir capacitor with a new component of the same value and voltage rating. If this process does not bring filament voltage to the correct level, the rectifier should be replaced by a new selenium unit of the same type. If a new selenium rectifier of *different* type, but with adequate voltage and current ratings, is fitted it would be advisable to temporarily insert a 500Ω variable resistor in series at the point marked with a cross in Fig. 1, bringing this down, when performance with the new rectifier is being checked, from maximum to minimum resistance until the potential across the filament chain reaches the requisite 7 volts. This precaution is desirable because the new rectifier may have a lower

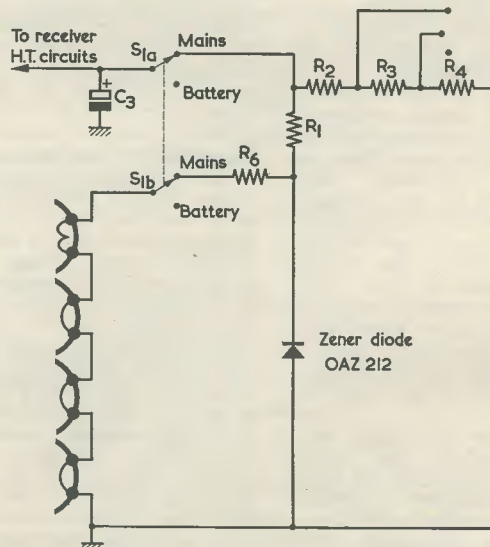

Fig. 2. Modifying the circuit of Fig. 1 for zener diode filament voltage stabilisation. Components and wiring not shown remain unmodified

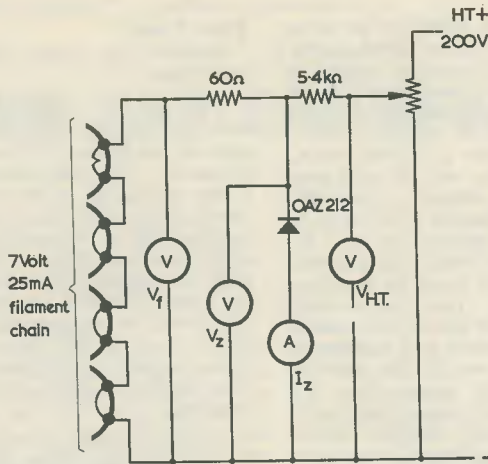

Fig. 3. The experimental circuit employed to check the usefulness of the OAZ212 for filament voltage stabilisation. The value of the potentiometer is not shown, as its only function is to provide a variable h.t. voltage. (The resistor shown as 5.4kΩ was a nominal 5.6kΩ component)

forward resistance rating than that for the one it replaces. If extra series resistance is needed, this fact will be indicated by the final setting of the variable resistor, which can then be replaced by a fixed resistor of the requisite value.

It is possible to burn out the filament of a 25mA valve merely by connecting a charged electrolytic capacitor to it. In consequence, no circuit alterations should be made to a mains-battery receiver switched for mains operation until the set has been switched off for several seconds in order that any electrolytic capacitors in the circuit may discharge. For the same reason, no valve should be removed or replaced until the set has been switched off for several seconds.

Circuit Modification

Whilst the procedure described above is frequently all that is required to bring a mains-battery portable into full working use as a mains receiver, it is obvious that greater reliability would be given by introducing some means of filament voltage stabilisation. This would obviate the dependence on mains supply voltage for correct filament voltage, and would also overcome the gradually falling filament voltage which results from age in the h.t. rectifier and reservoir capacitor.

A very simple and effective method of filament voltage stabilisation is illustrated in Fig. 2. Resistor R_1 is now terminated in a 9 volt zener diode type OAZ212, from which a further resistor, R_6 , connects to the filament chain. The voltage

across the zener diode remains very nearly constant despite changes in mains voltage or in the performance of the rectifier and reservoir capacitor, and the receiver becomes capable of giving a far more reliable long-term performance in consequence. Added to this is the fact that all valves run at the correct design filament voltage and therefore work under optimum conditions, both with regard to circuit operation and useful life. In order to provide a stabilising current for the zener diode, the values of R_1 , R_2 , R_3 and R_4 have to be reduced, and this point is discussed later.

To check the efficacy of the zener diode in a circuit of this nature, the writer assembled the

test set-up shown in Fig. 3. The voltage appearing at the reservoir capacitor in a mains-battery receiver is usually of the order of 200, and so it was decided to obtain readings at this voltage and below. The results are shown in Fig. 4, which shows the curves given by the Fig. 3 circuit for zener voltage (V_z), filament chain voltage (V_f) and zener current (I_z) at varying h.t. voltages tapped off by the potentiometer. At 200 volts, filament chain voltage is 7.1 and zener current is 11.5mA. At 156 volts, filament chain voltage is 6.8 and zener current is 2mA. Below 156 volts the zener diode starts to lose control and filament chain voltage begins to drop noticeably, being approximately 6.4 at 140 volts. It is obvious that the OAZ212 achieves minimum slope resistance after 2mA, as is confirmed by the published curves for this diode. The maximum direct zener current for an OAZ212 is 50mA, and the currents indicated in Fig. 4 are well below this figure.

The curves of Fig. 4 illustrate the fact that good stabilisation of the filament chain voltage is possible when zener current exceeds 2mA. The range of good stabilisation shown, 156 volts to 200 volts (at 11.5mA zener current), is a little greater than would be required in most practical instances. In consequence, the circuit of Fig. 3 could be adjusted so that zener current under the maximum reservoir capacitor voltage conditions likely to be encountered is, say, 10mA; whereupon good stabilisation will be achieved for reservoir voltages between the range covered by the ratio 194 to 156, or 1 to 0.8. (In Fig.

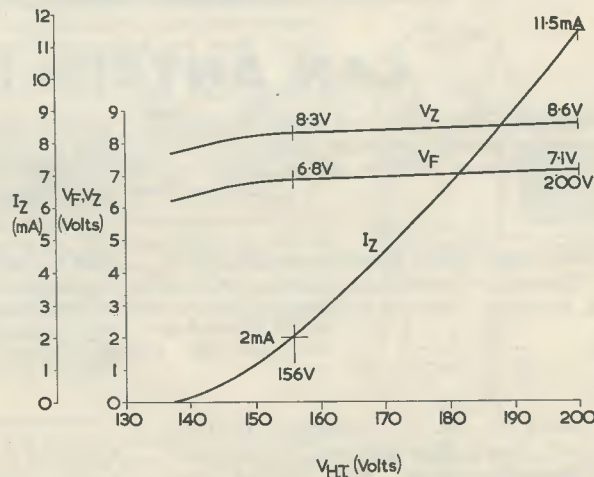

Fig. 4. The results obtained with the circuit of Fig. 3

4, 10mA corresponds to 194 volts.)

If, after bringing a mains-battery receiver into good condition for mains operation (this process including, if necessary, the fitting of a new reservoir capacitor and rectifier), it is decided to incorporate the zener diode circuit of Fig. 2, the writer would suggest that the following procedure be adopted. It is first of all necessary to find the voltage at which the particular OAZ212 that is to be used stabilises. This step is needed because the tolerance on the zener voltage of this diode is $\pm 15\%$. (There is little point, incidentally, in employing a 9 volt diode with a closer tolerance, such as the $\pm 5\%$ OAZ207, because the latter will be more expensive and it will still be necessary to find its actual zener voltage.) The zener voltage may be found by passing any current between 5 and 10mA through the diode and measuring the voltage across it. Once this voltage has been found, the value of R_6 can then be calculated and a physical resistor fitted. If, for example, it is found that the actual zener voltage is 8.5, then it is necessary for R_6 to drop 1.5 volts at 25mA. From Ohms Law, the resistance required for R_6 is 60Ω . A resistor of this value should then be fitted in the R_6 position.

It is next necessary to reduce the values of R_1 , R_2 , R_3 and R_4 (or the resistors in whatever equivalent series resistor chain is fitted in the receiver being modified) and this process may be conveniently carried out by connecting additional resistors in parallel with those already in

circuit. If it is intended to work to a zener current of 10mA under the maximum reservoir capacitor voltage likely to be given then it is helpful to remember that, under this condition, R_1 passes 35mA whereas previously it passed 25mA, and that R_2 , R_3 and R_4 will pass about 45mA whereas previously these resistors passed about 35mA. (The currents quoted for R_2 , R_3 and R_4 assume 10mA h.t. current, which is a typical figure for receivers of this nature). Thus the parallel resistor needed across R_1 could well be of the order of 2.5 times its present value, whilst the parallel resistors needed across R_2 , R_3 and R_4 could well be of the order of 3.5 times their present value. However, these figures are only intended as a guide and it is recommended that the resistor values be adjusted empirically such that the required zener current will flow under maximum reservoir capacitor conditions as monitored by a meter inserted in series with the zener diode. The parallel resistors initially added should have values higher than is given by the simple relationship just mentioned, these being reduced experimentally until the desired circuit conditions are obtained. When the adjustments are complete the h.t. voltage available at the junction of R_2 and R_1 should be of the order of 85 volts. It should be added that the h.t. rectifier employed must be capable of passing the zener current in addition to the h.t. and filament current. Assuming a maximum of 10mA zener current, the rectifier should be rated at at least 45mA.

Final Points

Several final points need to be mentioned.

The first of these is that the filament chain may have a thermistor such as the Brimar CZ10 connected across it. This component presents a low resistance in the event of a break in the chain due to a filament burning out or any similar reason, and it ensures that an excessively high voltage does not then appear on filaments above the break. The thermistor is not needed when the zener diode is in circuit, as the latter will perform the same function. The thermistor can, therefore, be removed.

A second point is that a zener diode stabilising circuit could also be used with mains-battery receivers having a 50mA filament chain. The writer has not, however, checked this application, although the introduction of the zener diode could follow the same procedure as has been described for a 25mA filament chain. It would be necessary to use a zener diode having a maximum zener current rating greater than that which would flow should the filament chain become open-circuit. In consequence, the OAZ-212, with its maximum zener current rating of 50mA, would not be suitable for use with a 50mA filament chain.

Finally, it should be pointed out that all adjustments to filament voltage should be made with the receiver switched on in the usual manner, so that the normal h.t. current is drawn by the valves.

CAN ANYONE HELP?

Requests for information are inserted in this feature free of charge, subject to space being available. Users of this service undertake to acknowledge all letters, etc., received and to reimburse all reasonable expenses incurred by correspondents. Circuits, manuals, service sheets, etc., lent by readers must be returned in good condition within a reasonable period of time

Ferguson 204XL and Berc Skyscraper Mk. II.—O. Zajac, 7 Wynnstay Grove, Manchester, 14—any information, purchase, loan or exchange.

* * *

R.F. Units 24 and 26.—A. G. Thompson, Thursley Cottage, Church Road, East Molesey, Surrey—any information on conversions. Also wanted copy *Practical Television*, July 1952.

HRO Receiver.—W. Bourke, 33 Victoria Street, Rutherglen, Scotland—any details of modifications r.f./i.f., bandspreading general coverage coils, etc. (15 metre bandspread has been completed, viz. *The Radio Constructor*, August 1958).

* * *

Colour TV.—E. Matthews, 63 The Oval, Newall, Otley, Yorks—full circuit details to construct colour TV.

NEWS AND COMMENT . . .

Welwyn Workshop

Some readers may already know of the "Workshop" in Welwyn Garden City, which was formed in 1961, to help the large number of youths who are mechanically minded but seem unable to fit into the average youth group.

The "Workshop" occupies a disused factory where young people can make and mend things with equipment provided at a fee of 2s. per session. It is not a club, there are no social facilities other than a stand-up tea bar, and the project is in charge of a "manager". No difficulty has been experienced in finding voluntary helpers ready to share their experience with the lads.

The experiment appears to be a great success, with the exception of the section dealing with radio and television. Although we were a bit surprised to learn this, it does seem that the majority of radio constructors are lone wolves, particularly those that, through force of circumstances, have to use the kitchen table as their workbench. On the other hand, we have always found constructors pleased to share their knowledge and help the newcomer to the hobby. Lack of someone to give a helping hand does inhibit the beginner very considerably as we know by the letters we receive from them. There are, however, many clubs affiliated to The Radio Society of Great Britain who run constructional courses, and any reader having difficulty in proceeding "under his own steam" may find it worth while to enquire from the R.S.G.B., at New Ruskin House, 28 Little Russell Street, London, W.C.1, as to the possibility of joining such a club within reach of his home.

Thinking Point

"... something I saw some time ago in one of the poorer countries. A man was ploughing a field. An emaciated ox drew a wooden plough and hanging from the plough was a transistor set. That is a measure of the world in which we live. The

poorest part of the world can be brought into the whole traffic of propaganda."

The Foreign Secretary during a Parliamentary debate.

British Tape Recording Contest 1965

"Mushrooms", a nine-minute programme featuring the Law Court confession of a future American President who destroyed China and the U.S.S.R., has been awarded the top prize in the 1965 British Tape Recording Contest. The tape, concerning the likelihood of a nuclear war, was entered by 19-year-old R. K. Partridge on behalf of students at Hertford College, Oxford. With the title "Tape of the Year", "Mushrooms" also wins the Emitape Challenge Cup and a £50 cash prize.

The judges, including TV conductor Eric Robinson, disc jockey Alan Freeman, and Timothy Eckersley (Assistant Head of Central Programme Operations (Recording) B.B.C. Ray King, 41-year-old photographic retailer, won the Mastertape Trophy, donated by Mastertape (Magnetic) Ltd., with "The Nose", judged best tape in the Humour Section. His five-minute light-hearted documentary included a representative selection of nose noises collected during a six-month research period into types and uses, linked with a skilful commentary.

Ten Silver Cups and Trophies were awarded together with cash prizes for four of the section winners. We were particularly interested that the winner of the professional section was F. C. Judd, A.Inst.E., who has written articles on electronic music for this magazine, as well as on other subjects of radio interest. His tape was entitled "Tempotone", an electronic music composition, and won the Scotch Cup donated by the Minnesota Mining and Manufacturing Co. Ltd.

Loudspeakers

The term loudspeaker has become very much a part of our language and when we use the term we

immediately visualise what it is, although if we were to take the word literally it would only be a means by which we heard broadcast speech.

It would make a fascinating study to discover how the terms a radio constructor uses gradually evolved. Forty years ago, for example, we used the term "wireless constructor", which reminds the writer of a broadcast by two comedians of that time, one asked the other "How do you make a wireless?" to which the other replied "It's simple. I get two wires, then take one away and I have a wire less." Our jokes were very unsophisticated in those days.

Returning to the subject of loudspeakers I can remember, as a small boy, placing headphones in a bowl or bucket in order to try and obtain resonance and a loudspeaker effect. Today the development seems to be in the opposite direction; the use of continuous tape to relay soft background music in restaurants and supermarkets, etc. Perhaps the cartoon below is apt in more ways than one.

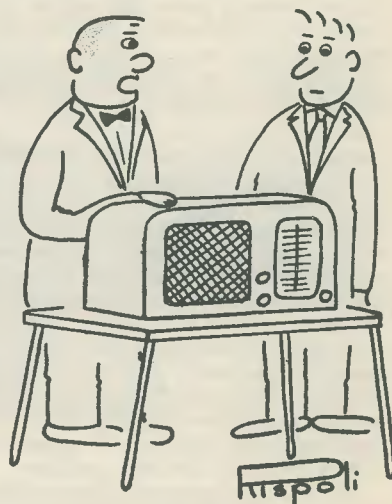

"A feature of its design is a 6 inch softspeaker!"

A Quality Multimeter

By W. KEMP

Part One

A fascinating aspect of radio work is the design of the more sophisticated type of multi-range testmeter. In this 2-part series our contributor describes a comprehensive home-built meter which has no less than 30 ranges. The basic movement requires an f.s.d. of 50 μ A whose internal resistance is unimportant. In this month's issue the basic development of voltage multipliers and universal shunts for d.c. and a.c., together with multi-range ohmmeter circuits, are described.

All of these lead up to the full and complete design which is featured next month

THE MULTIMETER TO BE DESCRIBED IN THIS SHORT series of articles is more advanced in design than most of the run-of-the-mill home built and "amateur" type commercial instruments, in that it has a total of no less than 30 ranges and, perhaps most important of all, has built-in automatic overload protection. Little difficulty should be experienced in constructing the meter as reasonably standard components are used throughout. The prototype multimeter was built at a cost of about £5.

Bearing in mind that some readers may prefer an instrument with ranges other than those stipulated or may require to use a different basic meter movement, as well as the fact that many readers new to the electronics game will not be familiar with the basic design procedure involved in making multi-meters, it has been decided to devote the first part of the series to the basic principles and design procedure involved.

Moving Coil Meters—Basic Considerations

The piece of apparatus that forms the basis of all multimeters is the moving coil milliammeter or microammeter. This instrument incorporates a coil of fine wire wound on a bobbin which is mounted on delicate bearings so that the assembly can move under almost frictionless conditions. Also mounted to the assembly is a pointer which projects over a graduated scale. The bobbin is mounted within the powerful magnetic field of a permanent magnet. Current may be fed to the coil via a pair of contra-wound phosphor-bronze springs which are fitted in such a manner that their tensions balance out when the pointer is in the zero position.

When current is passed through the coil a magnetic field is set up which interacts with that of the permanent magnet and applies a torque to the coil assembly. This rotates until a position is taken up

in which the torque is balanced by the force exerted by the phosphor-bronze springs. As the degree of rotation of the assembly, which includes the pointer, is directly proportional to the amount of current passed by the coil, it is possible to calibrate the meter scale directly in terms of current.

All moving coil meters, irrespective of the manner in which their scales are calibrated, work on this principle, and are therefore current-operated. Even if the scale is calibrated in volts this statement still holds true. In the latter case, resistance is added in series with the meter, and the voltage across the total series resistance of the circuit becomes proportional to the current which flows. The meter can then be calibrated in terms of voltage.

Any moving coil meter has two basic characteristics which are of importance. These are its sensitivity and its internal resistance.

The sensitivity of a meter is its current-indicating capacity and may be expressed in one of two ways, either in terms of its f.s.d. or as ohms/volt.

"F.S.D." stands for Full Scale Deflection, the f.s.d. being taken as the position in which the pointer is above the last marked graduation on the scale. Thus, if a meter is found to pass a current of 1mA under the f.s.d. condition, it is said to have a sensitivity of "1mA f.s.d."

The ohms/volt or ohms per volt figure is found by dividing the f.s.d. figure (in *amps*) into 1. Thus, 1mA f.s.d. equals $\frac{1}{0.001}$, or 1,000 ohms/volt. This figure is of value when converting a milliammeter or microammeter into a voltmeter.

The sensitivity of a meter will usually be evident from its scale; if not, it should be determined by comparison with a standard meter.

The internal resistance of a meter is the resistance of the actual coil assembly. This value may vary

between different meters from a fraction of an ohm to several thousand ohms. In some cases the value may be marked on the scale, in others it will be necessary to determine the precise value by the method to be described shortly.

Design Procedure

A basic meter movement can be made to measure ranges of current or voltage greater than those for which it was originally designed in a number of ways. The basic meter will, of course, respond to direct currents only, but by employing standard circuitry it can be made to indicate alternating quantities as well.

Internal Resistance

The basic method to be described of determining the internal resistance of a meter is the only one that can be used safely. *Any attempt to measure the resistance directly, such as with the aid of an ohmmeter, etc., may very probably result in severe damage to the basic movement.*

Fig. 1 shows the set-up for measuring the resistance. The idea is that the current through the internal resistance, r , of the meter is adjusted by VR_1 so that the meter is reading exactly f.s.d.¹. A shunt resistor, R_s , is then placed across the meter and the change in deflection noted. If, with the shunt in circuit, the needle were to fall to exactly centre-scale this would mean that half the f.s.d. current was passing through the meter and half through the shunt, so that the value of the shunt must be the same as that of the internal meter resistance. If, with the shunt in circuit, the needle takes up a position other than centre-scale the following formula may be used to determine the internal resistance:

$$\text{Internal resistance, } r = R_s \left(\frac{D_1}{D_2} - 1 \right)$$

where D_1 is deflection without shunt, and D_2 is deflection with shunt.

The value of the battery is shown in Fig. 1 as 9 volts, but it should be checked that, with the meter at f.s.d., the value of VR_1 is at least 100 times that of the estimated internal meter resistance. If not, use a battery with a higher voltage, as errors may otherwise enter the calculations due to non-constant currents through VR_1 .

D.C. Voltmeters

A milliammeter or microammeter may be made to measure voltage, as already mentioned, by adding a suitable resistor in series with the meter as shown in Fig. 2, the resistor being referred to as a "multiplier".

If a meter with an f.s.d. of 1mA is to be used to measure 1 volt f.s.d. then a multiplier resistor must be found of such a value that, when 1 volt is connected across the "volts" terminals, a current of 1mA must flow. If, for the moment, the internal

¹ VR_1 should, of course, have a track value which causes less than f.s.d. current to flow through the meter. Also, it should be initially set up to insert maximum resistance into circuit before the battery is applied.—EDITOR.

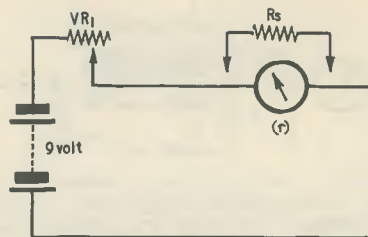

Fig. 1. Determining the internal resistance of a moving coil meter

meter resistance is ignored, it can be seen from Ohm's Law that the resistance is $\frac{E}{I}$ where E is the voltage and I the f.s.d. current of the meter. In this case the answer works out at 1,000 Ω , which is the same as the ohms/volt figure for a 1mA meter. If the voltmeter were required to measure 100 volts f.s.d., then the multiplier would be 100 times as large. It can be seen, then, that all that has to be done (ignoring the internal meter resistance) to convert to a voltmeter is to multiply the ohms/volt figure of the meter by the required f.s.d. voltage in order to arrive at the correct value of series multiplier resistance.

When the internal meter resistance is to be taken into account the formula becomes: $R_m = \frac{E}{I} - r$, where R_m is multiplier resistance and r is internal meter resistance.

To take two examples in the use of this simple formula, let it be assumed that a meter with 1mA f.s.d. and internal resistance of 100 Ω is to be used as a voltmeter measuring (a) 3 volts and (b) 30 volts f.s.d. The following results are obtained:

$$(a) \frac{3}{0.001} - 100 = 3,000 - 100 = 2,900\Omega.$$

$$(b) \frac{30}{0.001} - 100 = 30,000 - 100 = 29,900\Omega.$$

It will be noted that in the case of (a) the exclusion of r from the calculation would have resulted in an error of 3.3% in the final result whereas, in the case of (b), only an error of 0.33% would have resulted from excluding r . From this it can be concluded that the internal meter resistance can be ignored in cases other than when low voltages are to be measured.

When a voltmeter of this type is used to measure voltage it must draw a certain amount of current from the circuit under test, so the actual circuit conditions are altered by the mere act of taking a measurement. The larger the current drawn by the

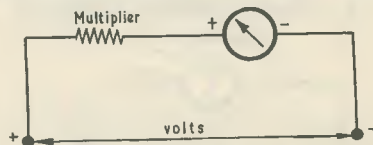

Fig. 2. A multiplier resistor enables the instrument to function as a voltmeter

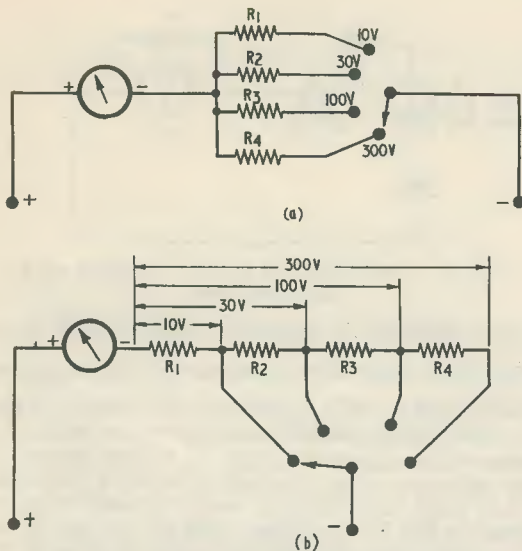

Fig. 3 (a). One manner of switching in multipliers for a multi-range voltmeter
(b). An alternative method of switching multipliers

meter the greater will be the change in circuit conditions, and the less likely will it become that the values indicated by the testmeter are the same as those which prevail under normal conditions. For this reason the meter used for measuring voltages should be as sensitive as possible so as to cause only a minimum change in circuit conditions.

For use in multimeters the basic movement should have a sensitivity of at least 1mA and preferably 50 μ A or better.

If several voltage ranges are to be incorporated in a meter, two possible methods of switching are available. These are shown in Figs. 3 (a) and 3 (b). To illustrate with an example, let it be assumed that a 1mA meter is to be used having ranges as follows: (a) 10 volts, (b) 30 volts, (c) 100 volts, and (d) 300 volts.

The multipliers required (r being ignored in all cases) are as follows: (a) 10,000 Ω , (b) 30,000 Ω , (c) 100,000 Ω and (d) 300,000 Ω .

In Fig. 3 (a) the values of R_1 , R_2 , R_3 and R_4 are quite straightforward and are as above. In the case of Fig. 3 (b), however, things are not quite as simple. R_1 measures the 10 volt range and will be 10,000 Ω . But the 30 volt range is made up of R_1 and R_2 in series, so R_2 will be 30,000-10,000 Ω =20,000 Ω . Likewise, (c) is made of R_1 , R_2 and R_3 in series so R_3 =70,000 Ω . By the same token, R_4 =200,000 Ω .

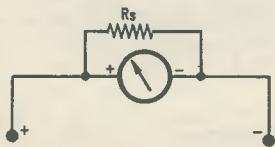

Fig. 4. Adding a shunt (R_s) across the meter increases its current f.s.d.

Extending Current Ranges

To extend the current range of a meter a "shunt" resistor is added across the basic movement, as shown in Fig. 4. A known fraction of the current to be measured is shunted through the shunt resistor, the remainder passing through the meter. If the relative ratios of current are known, the meter can then be calibrated directly in total current. If, for example, a 1mA meter were required to measure 50mA, then a shunt resistor would be chosen of such a value that $\frac{49}{50}$ of the current was

taken by the shunt and $\frac{1}{50}$ by the meter. It is therefore essential, in order to calculate the correct shunt value, to know exactly the internal meter resistance, r .

The formula giving the required value of the shunt, R_s , is $R_s = \frac{r}{n-1}$, where r is meter internal resistance and n equals the number of times by which the required range is greater than the basic range. In the preceding example, using a 1mA meter to measure 50mA, n would be 50. To take this example further, let it be assumed that the 1mA meter has $r=100\Omega$. Then the value of the 50mA shunt would be: $R_s = \frac{100}{50-1} = \frac{100}{49} = 2.04\Omega$.

It may be noted that if the same meter were to be given ranges of 1 amp and 10 amp as well, the required shunts would be 0.1001 Ω and 0.01 Ω respectively, the latter being a very low (but still practical) value indeed. Bearing these figures in mind, refer to Fig. 5 which shows an undesirable method of switching current ranges that may still be commonly used on some home-built multimeters and some of the lower class manufactured instruments. The switch is, of course, in series with the shunt resistor. Switches have a certain amount of contact resistance and, unfortunately, this resistance is not constant. It may vary in practice from a fraction of a thousandth of an ohm at one moment to one tenth of an ohm the next. In the latter case, and using the meter just discussed on the 10 amp range, an exceptionally high error in reading is possible. And what happens if a meter is out of use for some time and the contacts on one range oxidise? One may switch to the 10 amp range, to find that the relevant contact has oxidised and is effectively open-circuit. Well over 1 amp surges through the unshunted 1mA movement, whereupon there are clouds of smoke, and one meter is burnt out!

Special switches with very low and consistent contact resistance are available, of course, but these are very expensive and are fitted to only the very best meters. It is very strongly advised that the form of switching shown in Fig. 5 be left well alone unless absolutely necessary, in spite of the fact that some home-built multimeter circuit may be published which use the method.

There is, fortunately, a fairly simple alternative to the switching method of Fig. 5 for current ranges,

and it is the one that is used by all manufacturers of better quality multimeters. The system is known as the "universal shunt" circuit and is shown in Fig. 6. In this diagram only three ranges are shown, but the number may be extended as required.

It can be seen that the range resistors in Fig. 6 are all wired in series across the meter. The range switch is external to the shunt circuit, range-changing being effected by tapping into the shunt chain so that switch contact resistance has no effect on the ranges at all.

The first point to note with this circuit is that the meter is shunted on all ranges, so that the lowest range in use must be greater than the f.s.d. of the basic meter. If the range switch is in position "1", resistors R_2 and R_3 will be in series with the meter and R_1 will be in parallel with the meter-resistor combination. From this it would seem that the design procedure may be rather involved, since the effective meter series resistance is not constant but changes from range to range.

In point of fact the design procedure is simplicity itself but, in order to understand why, it is necessary to take a short exercise in simple algebra. This is made easier to follow if a working example is taken.

Let it be assumed that the 1mA meter with $r=100\Omega$ is to be converted into a multi-range meter having the following current ranges: (a) 3mA, (b) 30mA and (c) 100mA, the circuit being as Fig. 6.

The lowest (3mA) range will have the highest value of shunt resistance and this will be range 3, the total shunt being made up of R_1 , R_2 and R_3 in series. The first step in the design is to work out the shunt value to be used on the lowest range, then, and on this value all other values will depend. The formula given for the earlier current meter can be used, i.e. $R_s = \frac{r}{n-1}$, and this gives $\frac{100}{3-1} = 50\Omega$.

Therefore the sum of R_1 , R_2 and R_3 is 50Ω .

The next step is to work out the value of shunt needed for the highest range, which is range 3, reading to 100mA.

On this range, R_2 and R_3 are in series with the meter, and R_1 is in parallel with the combination. The formula already given therefore becomes:

$$R_1 = \frac{r + R_1 + R_2 + R_3 - R_1}{n-1},$$

it being realised that none of the individual values of the resistors, but only their sum, is known.² The formula becomes $\frac{100 + 50 - R_1}{100-1} = \frac{150 - R_1}{99}$. The value of R_1 can be

worked out by using cross multiplication, as follows: multiplying both sides by 99 gives $99R_1 = 150 - R_1$. Therefore, by adding R_1 to each side, $100R_1 = 150$, and $R_1 = 1.5\Omega$.

It may be seen from these calculations that, if a universal shunt with a reasonable number of ranges is to be built, the design procedure becomes rather tedious. A simplified system is clearly desirable.

If a few more quantities are represented by

² By adding $R_1 - R_1 (=0)$ to the numerator it becomes possible to introduce $R_1 + R_2 + R_3$, which is already known.—EDITOR.

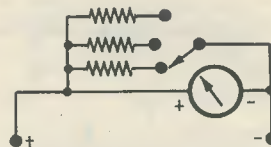

Fig. 5. One method of switching different shunts to obtain a multi-range current-indicating meter. As is explained in the text, this circuit is not recommended

symbols, the results which are now to be described are obtained, and all further calculations become "a piece of cake". Let R_s be the shunt value needed, with n and r the quantities as before, while R_s is the total shunt resistance as already worked out. The old formula for R_s now becomes: $R_s = \frac{r + R_t - R_s}{n-1}$. Transposing to get R_s on one side only,

this becomes: $\frac{r + R_t}{n-1} = R_s + \frac{R_s}{n-1}$, which breaks down further to $r + R_t = R_s(n-1) + R_s$, and even further to $r + R_t = R_s(n)$. By transposing again this finally becomes: $R_s = \frac{r + R_t}{n}$, which is simplicity itself.

Thus the shunt for the 100mA range is found to be $\frac{100 + 50}{100} = 1.5\Omega$, as before.

The value for the 30mA shunt is found next, but in this case it should be noted that the shunt is the sum of R_1 and R_2 . This is found to be $\frac{150}{30} = 5\Omega$.

The value of R_2 is therefore $5 - R_1 = 3.5\Omega$.

Similarly, the shunt value for the 3mA range is 50Ω , so the value of R_3 is found to be 45Ω .

It should be noted that all ranges are inter-dependent; a change in the value of one shunt resistor will effect the calibration of all other ranges.

A practical point to be noted is that in certain cases, such as if the meter now under discussion were to be given an additional 10 amp range, the value of shunt for the highest range may be very low indeed, only 0.015 Ω in this example. Such a low value of resistance would be difficult to construct with any degree of reliability, so it would be advisable to increase the total effective meter resistance by incorporating a "swamp" resistor in series with it, as shown in Fig. 7. The effect of the swamp is to raise the value of all shunts needed. In the example given, for instance, a swamp of

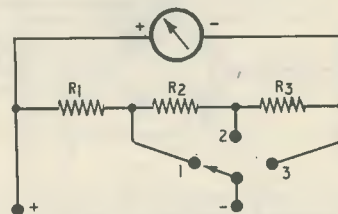

Fig. 6. The universal shunt circuit. With this arrangement the switch contacts do not enter the shunt circuit proper

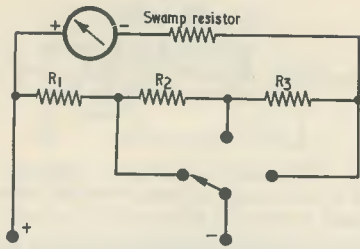

Fig. 7. If current ranges much higher than the meter f.s.d. are required, the shunt resistances may be very low in value and difficult to make up. Adding a swamp resistor in series with the meter necessitates higher resistance values in the universal shunt which are easier to provide. (The swamp resistor also reduces errors resulting from varying meter coil resistance with changes in temperature)

200Ω would make a total shunt of 150Ω necessary for the 3mA range, with corresponding increases throughout.

Alternating Voltage

To measure alternating voltage on a moving coil meter it is necessary to first rectify it, the normal method being by means of a bridge rectifier as shown in Fig. 8. Special instrument rectifiers are available for the job, but it will be found that if four ordinary germanium diodes are connected in bridge configuration results just as good as those of the special rectifiers will be obtained. Silicon diodes must *not* be used.³

All rectifiers have, of course, a non-linear action, and the nearer to the zero end of the characteristic curve that the device is worked the more non-linear it becomes. For this reason the rectifiers are usually operated from 0 to 1mA in moving coil a.c. voltmeters rather than from say 0 to 50μA, the loss in instrument sensitivity being more than compensated for by the improved scale linearity that results.

The meter will normally be calibrated for a sine wave input and will read r.m.s. values. In this case the meter has to pass a current of 1.11 times the pure direct current if true readings are to be obtained. The "multiplier" formula for alternating voltage

³ The author discusses differences in performance between germanium and silicon diodes in Part 2, to be published next month.—EDITOR.

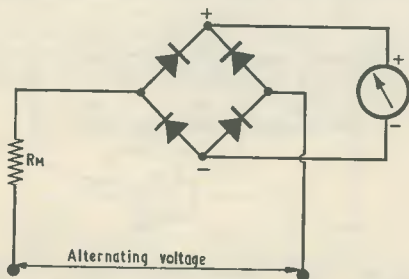

Fig. 8. A basic circuit for measuring alternating voltage, as discussed in the text

thus becomes: $R_m = \frac{E}{i \times 1.11}$, where i is normal f.s.d. current in amps, remembering that this will be at least 1mA, as mentioned.

It is important to note that on ranges below about 10 volts the scale readings will be non-linear, and the low ranges will need to be individually calibrated. It will also be necessary on the low ranges, to allow for the rectifier resistance as well as the internal meter resistance when constructing multipliers.

High quality commercial multimeters make use of a step-up transformer, increasing either the true voltage or current fed to the rectifier circuit, in order to overcome the non-linearity on low ranges that has been mentioned. The major disadvantage of this system is that the transformer places severe limitations on the usable frequency range of the instrument. No such limitation exists if only a bridge rectifier is used, and it will be found in practice that, with the circuit shown in Fig. 8, accurate readings from tens of c/s to hundreds of kc/s will be obtained, once the meter has been initially calibrated.

Alternating Current Ranges

The method used to measure alternating current in high quality commercial multimeters is to use a special transformer to step down the current to the basic meter. While suitable transformers *can* be designed and built by the amateur, often using trial and error methods, it is felt that such construction would be beyond the scope of most amateurs, and an alternative system which presents few difficulties will therefore be considered.

This alternative system operates in the following manner. A meter circuit is made up to read a fairly low value of alternating voltage and the scale, which will be non-linear, is then calibrated against a standard meter. The resulting circuit can be regarded as an a.c. milliammeter with a fairly high, but known, internal resistance, which can then be shunted in the normal way. The snags in the system are, first, the non-linearity of the scale and, second, the fact that the rectifier characteristics are likely to alter slightly with age. In practice the second of these points is found to be quite minimal, while the only trouble caused by the non-linearity is the difficulty of initial calibration. Even if the problems involved were greater than this, however, it cannot be denied that *some* kind of indication of a.c. current is far better than none at all!

As an example of the design procedure involved, let it be assumed that a microammeter is to be used to read the following ranges of alternating current: (a) 10mA, (b) 100mA, (c) 1 amp, and (d) 10 amp.

The first step is to shunt the meter so that it reads, say, 1mA f.s.d. No further comment is required on the procedure.

Next, the 1mA meter is made to read a *known* value of alternating voltage at a low level, the resulting circuit being similar to that shown in Fig. 8. As a low voltage range is being used, the rectifier resistance will make up a large portion of

the total circuit resistance, and as the rectifier resistance is likely to change with age, a limit is set on the *minimum* voltage range that may be used. Conversely, the higher the voltage range used, the higher will become the values of the shunts, and for measuring current the shunt resistors should be of the lowest possible value if true indications of circuit conditions are to be obtained.

For example, a range of 1 volt a.c. may be taken and the multiplier is therefore found, from the

formula $R_m = \frac{E}{i \times 1.11}$ to be 900.9Ω. As the rectifier

resistance value is unknown, the only procedure that can be used is to connect a 1,000Ω variable resistor in place of the multiplier and adjust its value, while comparing the meter calibration with that of a standard meter, until the required f.s.d. reading is obtained. Now, although none of the *individual* resistances of the circuit may be known, it is known that the *total* circuit resistance is 900.9Ω with the meter at f.s.d., and it is also known that the f.s.d. is 1mA. With these facts in mind the circuit can be shunted in more or less the normal way, to read higher ranges of current. If a universal shunt is used, the design procedure takes the following steps.

Total shunt resistance, used on range (a), 10mA, is given from the formula $R_s = \frac{r}{n-1}$ and is found to be 100.1Ω. Therefore, total series resistance is 900.9 + 100.1 = 1,001Ω. Therefore, the 10 amp shunt is $\frac{1,001}{10,000} = 0.1001\Omega$.

The 1 amp shunt is $\frac{1,001}{1,000} = 1.001\Omega$, therefore the 1 amp resistor is 1.001 - 0.1001 = 0.9009Ω.

The 100mA shunt is 10.01Ω and the 100mA resistor thus equals 9.009Ω.

The 10mA shunt is 100.1Ω and the 10mA resistor thus equals 90.09Ω.

The complete circuit, as above, is shown in Fig. 9.

Resistance Ranges

The basic resistance measuring circuits are shown in Figs. 10 (a), (b) and (c).

The most generally used circuit is that shown in Fig. 10 (a) and is known as the "series-connected ohmmeter". In use the X terminals are first short-circuited together and the variable resistor adjusted to bring the pointer to f.s.d. The unknown resistor is then connected between the X terminals and the new current reading noted. The unknown resistance

can be calculated from the formula: $R_x = \frac{R \times i}{I} - R$.

where *i* is f.s.d. current, *I* is the new current reading and *R* is the *total* resistance of the ohmmeter, which is the product of the battery voltage and meter f.s.d. current. To calibrate the scale a graph can be plotted from, say, ten sets of calculations and the scale then calibrated directly from the graph. Alternatively, the scale may be calibrated against known values of resistance.

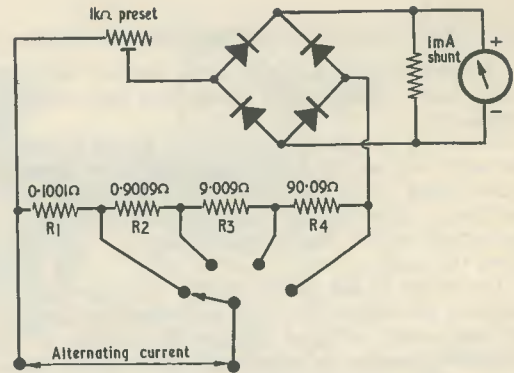

Fig. 9. A basic multi-range a.c. ammeter with calculated universal shunt values

A useful feature of this circuit is that, once the scale has been calibrated, the meter may be shunted to a known ratio of f.s.d. and the calibrated scale still holds good if it is divided by that ratio. If, for example, the ohmmeter were calibrated using a meter of 1mA f.s.d., it would then be found that if the meter were shunted to read 10mA f.s.d. the calibration would give a correct indication of resistance if all readings were divided by 10.

The circuit shown in Fig. 10 (b) is known as the "shunt-connected ohmmeter". The method of use here is to first adjust to f.s.d. with the X terminals *open-circuit*. Once this has been done the unknown resistance is connected across the terminals and the new reading noted. The value of the unknown resistance may be calculated from the formula:

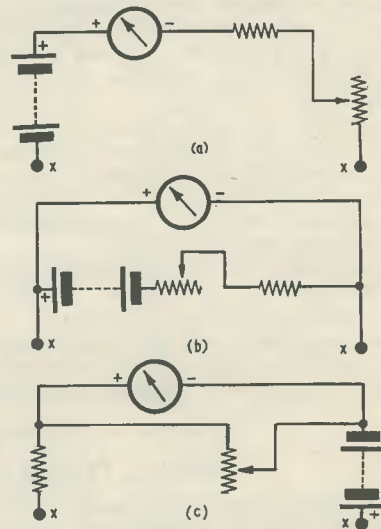

Fig. 10 (a). The series-connected ohmmeter
(b). The shunt-connected ohmmeter
(c). An alternative ohmmeter circuit which is employed in the same manner as the series-connected ohmmeter of (a)

$R_x = \frac{r \times i}{i - I}$, where r is internal meter resistance, i is f.s.d. current and I is the new current indicated. This circuit is useful for measuring low values of resistance.

The third circuit, shown in Fig. 10 (c), is used in the same way as the series-connected ohmmeter, the meter being set at f.s.d. with the X terminals short-circuited, after which the unknown resistor is connected across the terminals and its value read from the scale.

The value of the series resistor used is made the same as the required centre scale reading (in terms of resistance) of the meter. The value of the unknown resistor is calculated from the formula:

$R_x = R \left(\frac{i}{I} - 1 \right)$, where R_x is the unknown resistor, R is the resistance of the series resistor, i is the f.s.d. current and I is the new current indicated.

To take an example, a 1mA f.s.d. meter has a centre scale value, and therefore a series resistor, of 1,000Ω. After the ohmmeter has been set up, an unknown resistor is connected across the terminals and a new current reading of 0.4mA is observed. What is the value of the unknown resistor?

From the formula it is found that $R_x = 1,000 \left(\frac{0.001}{0.0004} - 1 \right) = 1,000 (2.5 - 1) = 1,000 (1.5) = 1,500\Omega$.

Once again, the scale is best calibrated by making a graph from several such calculations and then transferring to the meter scale.

Second Part

In the second and concluding part of this series, to be published next month, the full circuit of the complete multimeter with built-in overload protection will be given, along with full constructional information.

Simple Transistor Tester

★★★★ B. ANDREWS ★★★★★

THIS SHORT ARTICLE DESCRIBES A SIMPLE BUT very useful transistor testing circuit. It can be built into a small box and proves invaluable for giving transistors of all types a quick check to see whether or not they are functioning.

The Circuit

The circuit consists of a 4.5 volt battery, three fixed resistors and a potentiometer as shown in the diagram. The transistor under test is connected by means of three flying crocodile clip leads into a common emitter circuit.

An Avo Model 8 on the 2.5 volt range is then connected across the 10kΩ "load" resistor, R_4 , and reads the volts dropped across it. Any similar voltmeter circuit offering a full scale deflection of 2.5 volts and a resistance of approximately 10kΩ may be employed instead.

As the potentiometer slider is turned from the positive line towards the negative potential the meter will read from about 0.1 volts to 2.5 volts. Faulty transistors will not, of course, give this result.

The 2.7kΩ resistor, R_1 , prevents the transistor

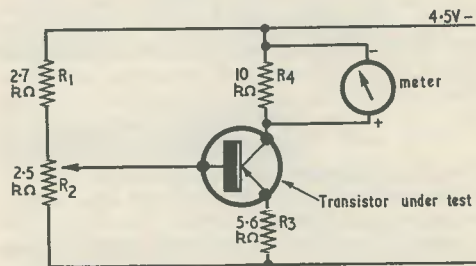

The circuit of the simple transistor tester. The meter is a high resistance model switched to a 2.5 volts range

being made to conduct "flat out" with resultant damage.

For n.p.n. transistors the battery connections should be reversed, and a switch could be incorporated in the unit to accomplish this.

This circuit is also useful for newcomers to transistors, as it helps demonstrate how they operate.

"SEMICONDUCTOR DIODE CIRCUITS"

A new 27-frame colour filmstrip entitled "Semiconductor Diode Circuits" is announced by the Mullard Educational Service. It forms part of a series covering advanced electronic circuitry and is intended for use in technical colleges, universities, industry and the services.

The strip describes the construction and theory of semi-conductor diodes and their use in power supply units, radio and television, computers and miscellaneous applications.

Copies may be ordered from: Unicorn Head Visual Aids Ltd., 42 Westminster Palace Gardens, Artillery Row, London, S.W.1.

Price 25s. per strip including comprehensive teaching notes.

In your Workshop

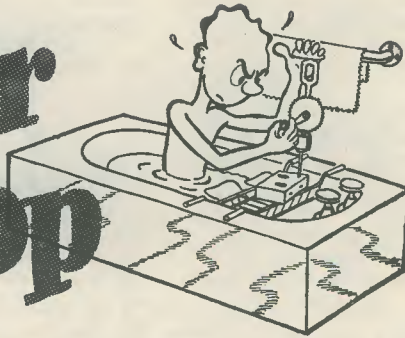

Life for the service engineer is not always a matter of peaceful routine, and it can become particularly unpredictable when he has to work, as does Smithy, with a bench mains supply that is liable to disappear without warning. Even so our doughty Serviceman is still able to give his able assistant, Dick, some insight into the mysteries of mains modulation and medium wave breakthrough on TV

RECIPE FOR MINOR CONTENTMENT: Take one brand-new replacement component out of its box and observe that its solder tags are bright and nicely tinned. Mount component on chassis and pass connecting leads through its tags, clinching over if necessary. Take one length of resin-cored solder and one well-tinned soldering iron of just the right wattage. Apply solder and soldering iron simultaneously to each tag in turn, noting how the solder flows cleanly over the contiguous surfaces of tag and wire. Remove solder and soldering iron then stare contentedly at component and connections, conscious of the special satisfaction that results from a job which has obviously been very well done.

Thus it was with Dick as he gazed, one September morning, with rapt expression at the tags of the replacement volume control and switch he had just fitted and wired up. He had picked out the 405 line television chassis which now lay on his bench with the confidence that follows several hours of uncomplicated and successful repair jobs, and his air of self-reliance had deepened when he found straight away that there was no familiar click when the receiver's combined volume control and on-off switch was turned. He had immediately set to work to remove what was obviously a component with a simple mechanical fault, and to fit a replacement. And he now sat looking fondly at the excellent solder joints which he had just completed.

Shaking himself out of his reverie, Dick inserted the mains plug of the receiver into the appropriate socket in the row at the rear of his bench and switched on.

Switch Wiring

Two things happened.

First, a loud crack came from the long-suffering fuse-box over the Workshop door. Second, there was a grunt of disgust from Smithy the Serviceman, to be followed by the banging of his soldering iron as it was forcefully returned to its rest. Smithy turned round to face his assistant.

"You have," he remarked mildly, "done it again."

"Now, don't be like that," replied Dick hastily, "it's ages since I last blew the fuse."

"No, it isn't," said Smithy. "The last time was yesterday afternoon. You're *always* blowing the fuse."

"Is it *my* fault," retorted Dick, stung by the injustice of Smithy's accusation, "if the sets I repair have a high proportion of mains shorts on them?"

"I should imagine," commented Smithy wearily, "that the Central Electricity Generating Board must have to lay on a special generating plant during working hours just to cope with the surges which you put on the Grid when you're repairing sets. If the amps you've tried to force through that poor old fuse-box since you've been here were multiplied by the mains voltage, you'd be well in the megawatt class by now!"

But Dick had no ears for Smithy's complaints, and had already moved his stool over to the door.

"What grieves me," continued Smithy sadly, as he watched his assistant climb precariously on to his stool and open the fuse-box, "is that I should have been misguided enough in the first place to have had your bench run from the same fuse as my own. Servicing, for me, consists nowadays of working like the clappers during the infrequent periods when the mains is on, and then spending long periods of inaction whilst I watch you wobbling around on that stool at the fuse-box."

"I won't," said Dick, busy with the fuse wire, "be a minute."

"I was just," grumbled Smithy, wandering over and looking idly at the television chassis on Dick's bench, "on the point of pinning down a real stinker of an intermittent when that fuse blew. It'll take me a good quarter of an hour now to get everything cooked up again. Hello, what's this?"

"What's what?"

"This set."

There was an ominous note in Smithy's voice.

"It's the one that blew the fuse," replied Dick carelessly. "I'd just changed the volume control and switch, then turned it on. Whereupon the fuse blew."

"And no wonder," snorted Smithy angrily. "Talk about cack-handed! You've wired the switch up so that it neatly shorts out the mains every

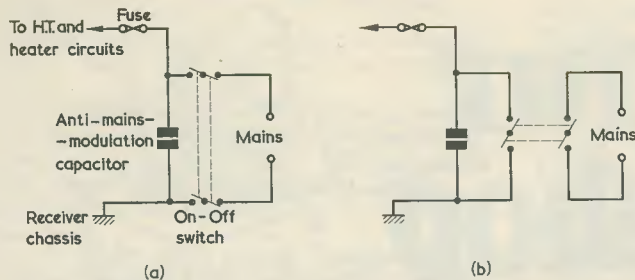

Fig. 1 (a). The on-off switching circuit in the receiver serviced by Dick
(b). Dick's first attempt at re-wiring the switch resulted in the circuit shown here

time you turn it on!"

Hastily Dick closed the lid of the fuse-box and calmed down off his stool.

"I don't get you," he said. "How on earth could it do that?"

"I should have thought," commented Smithy irritably, "that it was dead obvious."

He pulled a ball point pen from his overall pocket.

"Look," he said, scribbling on Dick's notepad. "Here's the circuit which that switch is supposed to control. (Fig. 1 (a).) It's typical of the normal double-pole on-off mains input circuit that you get in TV sets, and it's as simple as you could possibly have. Right?"

"Right."

Dick still looked puzzled.

"But you," growled Smithy, "aren't satisfied with anything as straightforward as that. What you have to do is to wire that blanketly switch up like this. (Fig. 1 (b).) So that the mains is shorted whenever you switch it on!"

"I see what you mean, now," said Dick, light breaking in. "Still, a little thing like that could happen to anyone. There are four tags on the switch spaced out in no particular pattern that I can see, so how are you to know which tags are which?"

"Well, I know," replied Smithy, "because, in this instance, I've been handling switches of the type and make you used for a long time now. But if ever I'm doubtful about the tags on a double-pole switch fitted to a volume control, I always check through with an ohmmeter before connecting up. All you do is turn the switch on and find the pairs of tags which have continuity between them. What you'll have to do now is whip off all the wires from that switch, identify the tags with an ohmmeter, and then rewire it all up again. Only, this time, do it properly!"

With which parting shot Smithy

left his assistant and stalked back to his bench to resume the assault upon his intermittent fault.

Mains Modulation

Regretfully, Dick unsoldered the joints over which he had taken so much care and proceeded to carry out Smithy's instructions. Having, with his testmeter, found the tags corresponding to the switch poles, he once more refitted and soldered the wires which connected to them. His spirits rose at the thought of another repair nearly completed, and he whistled cheerfully as he inserted the plug of the receiver into its socket at the back of his bench.

He switched on.

There was, immediately, a loud crack from the fuse-box over the Workshop door. This was followed by a furious crash as Smithy's soldering iron once more returned forcibly to its rest. The Serviceman turned round and directed a glowering eye on his assistant.

"You've done it *again*," he fumed. "Within five minutes of the last time, you've done it *again*. You must be one of those blokes who're fascinated by wrecking electrical things. I should imagine you spend your spare time throwing bicycle chains over electric train wires and things like that."

"That's not fair," protested Dick. "I wired up that switch *exactly* as you said."

Smithy walked over and peered at the component.

"Well," he remarked, mollified, "I'll agree with you there. You must have a dead short immediately after the switch. The anti-mains-modulation capacitor is a fair bet."

Smithy pointed to a capacitor mounted close to the switch. Dick quickly snatched up his already cooling soldering iron and swiftly unsoldered one of its leads. He applied his test prods across the capacitor (Fig. 2) and watched the

needle of his testmeter, which was still set to the ohms range he had used for identifying the switch tags.

"It's showing," he announced, "a dead short."

"Good," replied Smithy, pleased at the accuracy of his diagnosis. "Well, bung in a new capacitor, and don't forget that it must be rated at 300 volts a.c. working. All the time the set is switched on, that anti-mains-modulation capacitor has to run with the full mains voltage across it."

"Fair enough," said Dick. "Incidentally, I've never really been certain what an anti-mains-modulation capacitor is for."

"It's to prevent," replied Smithy, "mains modulation!"

"I know that," said Dick impatiently, "but how does it work?"

"It works," said Smithy, "by bypassing the mains for r.f., with the result that varying impedances at the mains supply terminals cannot enter the aerial signal circuit path."

"I am most indebted to you for that statement," commented Dick politely. "The only trouble is that I haven't the faintest clue as to what it means!"

"Mains modulation," conceded Smithy, "is rather a difficult subject to put over. Perhaps I'd better briefly explain some of the forms it can take up. If a receiver suffers from mains modulation, or 'modulation hum' as it's also called, there is no trace of hum in the output if the set is not tuned to a station. As soon as a transmission is picked up, however, the received signal becomes modulated by the mains frequency. Sometimes the effect will only occur with input signals of certain strengths. With sound receivers, the result of mains modulation is a characteristic gurgling type of reproduction. When people speak, it sounds as though they want to clear their throats. The result is rather the same as if you'd inserted an electric guitar vibrato circuit into the a.f. stages of the receiver with the difference that, with mains modulation, the vibrato frequency is that of the mains instead of the 10 c/s or so that you have with guitar vibrato circuits. On a TV set, you're liable to get contrast level varying as you go down the picture. Think of hum bars on the picture, then imagine the same idea but with contrast varying instead of the raster going brighter and darker. I should add that mains modulation on picture is a pretty rare manifestation and that one of the things that can enable you to diagnose it is the fact that it's only present when a signal is being received."

"I think," commented Dick, "I get the idea."

"Fine," said Smithy. "Let's next consider the mains input supply in an a.c./d.c. radio, or television receiver. As you know, this normally feeds directly into a half-wave rectifier which conducts during positive half-cycle peaks and which acts as an open circuit for the rest of the time. So the impedance at the mains input terminals of the receiver varies during each cycle, becoming smaller when the rectifier conducts. This change in impedance occurs at the frequency of the supply mains, and it is quite possible for the varying impedance to enter the aerial signal path of the receiver. Now, there is a small mismatch in the aerial input circuits of many TV receivers working on Bands I and III, this being due to the aerial isolating capacitors in the set. The mismatch causes aerial signal currents which should run harmlessly into the tuner to tend, instead, to radiate a little and to become affected by adjacent circuits. An aerial input circuit of this nature could quite conceivably be susceptible to an impedance which varies at 50 c/s and which appears in the path between the receiver chassis and earth, or in the path between the receiver chassis and a long length of unscreened mains lead and wiring."

"I suppose," said Dick, "that this varying impedance could then modulate the input signal."

"It's quite possible," agreed Smithy. "But what I've just mentioned is what, to my mind, represents a fairly obvious cause of mains modulation. In this instance you get rid of the varying impedance at the mains input terminals by slapping a large value capacitor across them to bypass r.f. With TV sets this capacitor is usually of the order of $0.1\mu\text{F}$, whilst with sound radios it would be between $0.1\mu\text{F}$ and $0.01\mu\text{F}$. I must say straightaway that the effect I've just described doesn't cover all causes of mains modulation by any means, but it can give you an idea of the manner in which it occurs with things like TV sets. Mains modulation was very prevalent with sound a.m. radios some years ago, but that was for a different reason."

Bottom-End Coupling

"Oh yes," said Dick, interested. "What happened then?"

"Many a.m. receivers," replied Smithy, "had bottom-end aerial coupling circuits for medium and long waves in which aerial coupling was achieved by connecting the aerial to a fairly large value capacitor

inserted at the lower end of the tuned coil. This was known as the bottom-end capacitor, and the basic arrangement was something like this."

Smithy scribbled a circuit on Dick's pad. (Fig. 3 (a).)

"Now the aerial," continued Smithy, "was the bit of wire that was popular before ferrite rod aerials became the order of the day and it had, of course, a capacitance to earth. If the receiver was connected to the mains so that its chassis was live you could then say that an a.c. generator knocking up about 240 volts r.m.s. was applied between this chassis and earth. Add in the aerial-earth capacitance (Fig. 3 (b)) and you have a capacitor potentiometer which will cause quite a sizeable proportion of the 240 volts a.c. to appear across the bottom-end capacitor. This voltage would cause mains modulation of the signal, and the effect was normally prevented by having a fairly low value resistor between the aerial input and chassis to bypass the 50 c/s voltage without losing too much signal voltage. The resistor was connected into circuit like this (Fig. 3 (c)) and I've shown it as having a value of the order of 5 to $10\text{k}\Omega$. Even then you might get mains modulation with certain installations, but this was usually cleared by reversing the mains plug of the receiver and ensuring that the chassis was at neutral potential. So that's an instance of another type of mains modulation."

"Bottom-end coupling," commented Dick, "is a bit old-fashioned nowadays, isn't it?"

"On the contrary," replied Smithy. "It's come back again and is now being fitted to quite a number of present-day a.m. sound receivers. These are the larger type of mains-operated set, and they use a ferrite rod aerial in the usual modern

manner. But many of these sets are provided with aerial terminals which couple into the ferrite rod tuned circuit by way of a bottom-end coupling circuit which is exactly the same as those that were used in the earlier sets. And so the old bottom-end coupling circuit is once more amongst us!"

"Plus ça change," commented Dick, unexpectedly, "plus c'est la même chose."

"What did you say?"

"Plus ça change," repeated Dick, "plus c'est la même chose."

Smithy regarded his assistant doubtfully.

"Oh," he said after a moment. "Well, there we are then. Where was I?"

"Finishing off mains modulation," replied Dick helpfully, "with bottom-end coupling circuits."

"Oh yes, so I was," said Smithy, getting back into his stride. "Well, I've got nothing more to say about bottom-end coupling and I've now given you two possible instances of how mains modulation may occur. In practice, you'll bump into quite a few more. Nearly always, with a.c./d.c. sets and assuming that it's not a faulty bottom-end aerial input circuit, the cure is to slap a capacitor across the mains leads to act as an r.f. bypass. That capacitor then performs the secondary function of preventing any r.f. interference in the mains from getting into the receiver. I ought to mention that you get rather a similar effect to mains modulation if the h.t. supply to the receiver oscillator isn't sufficiently smoothed. The oscillator anode voltage then varies at the ripple frequency, causing this ripple frequency to frequency-modulate the i.f. The result can sound rather like mains modulation of the type I've just described and it similarly appears

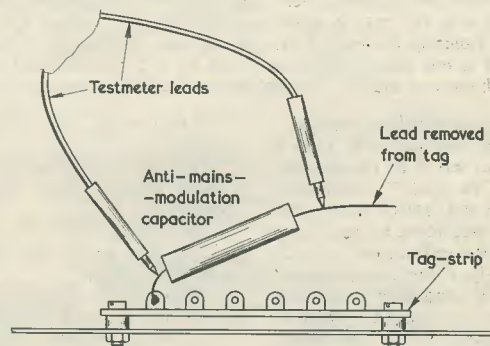

Fig. 2. To confirm that the anti-mains-modulation capacitor was short-circuited, it was necessary to disconnect one of its leads from the external circuit before checking it. If the capacitor had been mounted on a printed circuit board one of its leads could have been snipped

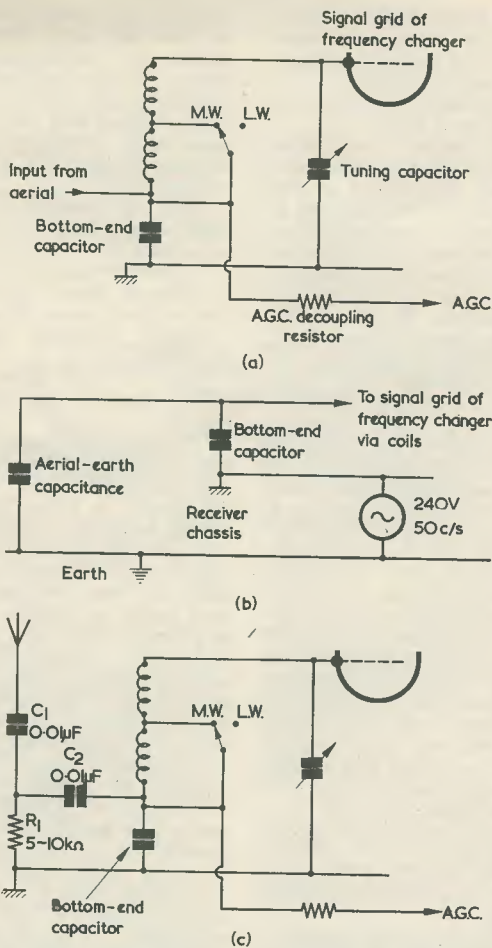

Fig. 3 (a). The basic bottom-end coupling circuit for medium and long wave reception. The bottom-end capacitor has a value of, typically, 5,000pF
 (b). If the aerial is coupled directly to the bottom-end capacitor in an a.c./d.c. receiver, the circuit shown here is set up when the receiver chassis is at live mains potential
 (c). To prevent mains modulation, the resistor R_1 , connected between the aerial input and chassis, is given a relatively low value. Capacitor C_1 is an aerial isolating component (needed because the chassis of the receiver is connected to one side of the mains) and C_2 is a d.c. blocking component which ensures that R_1 does not appear across the a.g.c. circuit

only when a signal is being received.”
 Smithy took his pen off Dick’s bench and returned it to his pocket. “And now,” he said, “I must start thinking about that set of mine, and you’ll need to get down to replacing that anti-mains-modulation capacitor. Incidentally, it has just occurred to me that this capacitor may have been the reason why the original switch went faulty in the first place. Perhaps the contacts got welded together or something like that. You’d better ensure that the new switch is working O.K. before you let the set go.”

“Okeydoke,” said Dick. “I’ll do that.”
 “Good,” commented Smithy. “And now I must return to my bench.”
 He paused.
 “By the way,” he asked, “what was that, again?”
 “What was what?”
 “What you said just now.”
 “Plus ça change,” repeated Dick obligingly, “plus c’est la même chose.”
 “Oh, I see.”
 “It seems to me to be a fitting comment.”

“Yes, of course.”
 There was silence for a moment. “Oh, well,” said Smithy, finally making ready to go. “I’ll get back to my own work now.”
 “Righty-ho,” replied Dick cheerfully, “and I’ll get the fuse fixed.”
 The repair of the fuse was carried out very quickly and efficiently by Dick (who was not without previous experience in this task) and Smithy grunted with satisfaction as the equipment on his bench once more came to life.

Home Service on TV

Dick next proceeded to occupy himself with the replacement of the broken down anti-mains-modulation capacitor which had wreaked such havoc with the Workshop fuse, after which, and for the third time that morning, he inserted the plug of the television receiver into its socket at the rear of his bench. With considerable trepidation he turned the receiver on.

This time everything proceeded normally. After a few moments, the valve heaters gave a comforting red glow, and a quiet hiss became audible from the loudspeaker. Shortly afterwards the booster diode reached operating temperature and the line output transformer began to sing merrily away. After a few further seconds the e.h.t. rectifier came into operation, and a faint white raster appeared on the screen.

With a grin of satisfaction Dick reached round, picked up one of his testmeter leads and inserted the test prod into the centre aperture of the receiver’s coaxial aerial socket. As soon as this makeshift aerial was applied the line output transformer whistle rose to 10,125 c/s as the line timebase locked in, the loudspeaker reproduced a burst of music and the screen gave a noisy but otherwise quite acceptable reproduction of the local I.T.V. programme.

Quickly, Dick flipped the tuner over to the local B.B.C. channel, to be rewarded by a reasonable picture with slight ghosting, and by excellent sound. The receiver seemed to be in very good order and it certainly had sufficient sensitivity to pick up the two local channels with only a few feet of wire on the bench as an aerial.

Dick took out his temporary test lead aerial and reached over to pick up the coaxial cable leading to the outside aerial on the roof. He plugged the coaxial lead into the aerial socket of the receiver. A picture was at once resolved which was completely free of ghosting and noise, but it showed evidence of intermittent line lock together with

what appeared to be sound on vision. Occasionally, the vertical timebase went out of synchronism and the picture rolled once or twice before falling into lock again. There seemed to be something wrong with the sound from the loudspeaker as well. There was a continual background of music which did not accord with the television programme at all.

At that moment the television programme came to an end, whereupon the screen reproduced the familiar B.B.C. interval signal, and the loudspeaker became silent. All of a sudden the loudspeaker gave voice.

"This," it remarked, "is the B.B.C. Home Service."

Dick listened incredulously over the following few seconds as the loudspeaker reproduced the Home Service transmission, after which the next television programme commenced. This proceeded in normal fashion, but both picture and sound were accompanied by what was now an obvious background provided by the Home Service. Hastily, Dick switched back to the I.T.V. channel, only to find that the Home Service was, similarly, providing an unwanted background to the I.T.V. signal. He switched in desperation to a dead channel, but all that happened was the appearance of a perfectly blank raster on the screen and a quiet hiss from the loudspeaker.

Dick turned the tuner back to the I.T.V. channel and looked unbelievably at the unstable picture with its accompaniment of I.T.V. cum Home Service sound.

"Blimey," he murmured to himself, in an awe-struck tone, "this set has got a *fault!*"

In the absence of any greater inspiration, he examined the components immediately following the aerial input socket. These comprised a perfectly normal combination of isolating capacitors and static discharge resistors. (Fig. 4.) Suddenly, a thought struck him. What would happen if he earthed the outer conductor of the aerial coaxial cable?

The soldering irons and other mains equipment on Dick's bench were not earthed, but an earth terminal was provided for any occasional test that required such a connection. Dick quickly picked up one of the crocodile clip leads he kept on hand for temporary hook-ups, connected one end to the earth terminal and the other end to the outer conductor of the coaxial cable. A convenient solder tag to which the crocodile clip could be attached

appeared behind the Paxolin panel on which the aerial socket was mounted.

As soon as the earthing clip touched the tag the Home Service programme disappeared. An excellent picture with excellent sound was reproduced. Delighted, Dick swung the tuner to B.B.C. Again, everything was as it should be. The Home Service background had vanished as mysteriously as it had appeared.

It was at this instant that Dick's guardian angel, who had been putting up quite a commendable performance over the last few minutes, suddenly realised that he was at least a minute into tea-break, and hurried off in the direction of the G.A. Canteen.

Unconscious of the fact that his attendant spirit had deserted him, Dick turned his attention to the aerial isolating capacitors. The one on the earthy side of the aerial input circuit looked a little out of position, and Dick picked up a small screwdriver to give it a prod. In so doing, he accidentally short-circuited the capacitor lead-out wires.

Filter Choke

There was, at once, a loud crack from the fuse-box over the Workshop door, this being followed, for the third time that morning, by the infuriated crash of Smithy's soldering iron on its rest.

"Stone the blistering crows," roared Smithy, as he turned round yet again to face his assistant. "You've been and gone and done it all over again! Three times in twenty minutes you've blown that fuse, and in each case you've done it when I'm just on the point of catching that intermittent of mine."

"I'm sorry, Smithy," said Dick. "But it really *was* an accident this time."

"It couldn't have been an accident," exploded Smithy. "You *can't* just keep on blowing fuses at a rate of nine per hour and say it's an accident."

"Well, I really am sorry," said Dick contritely, "and, as I said, it really was an accident."

But Smithy was not to be placated. "It couldn't *possibly* have been," he raged. "*Nobody* can have accidents as often as you have accidents."

It was evident that Smithy was going to continue in this vein for a very considerable time unless sharp and decisive action was taken.

Fig. 4. A typical television aerial isolating circuit for Bands I and III

Courageously, Dick decided to take that action.

"I still think," he said, slowly and distinctly, "that they were entitled to their M.B.E.s."

Smithy stiffened.

"Ye gods," he snorted, visibly shaken by the sudden change of subject, "don't bring *that* up again! I nearly had apoplexy during our arguments over that one!"

The Serviceman fell silent as the memory of previous heated disputations rose in his mind. Suddenly he chuckled.

"All right, Dick," he grinned. "You win! Perhaps I was blowing my top a bit just now."

Dick immediately took advantage of Smithy's change of outlook. Service in the G.A. Canteen must have been exceptionally swift that morning.

"This set," he announced, hastily, "reproduces both the B.B.C. and the I.T.A. with the Home Service sound programme in the background."

"Does it?" said Smithy, a gleam of interest rising in his eye.

"And," continued Dick, hurriedly consolidating his position, "there is no breakthrough when I switch to a dead channel. It's only when I switch to a channel on which there's a transmission."

"Well, now," commented Smithy "that *is* interesting."

"The breakthrough," Dick carried on, secure in the knowledge that Smithy was now well and truly hooked, "only occurs if I use the outside aerial, and it disappears when I earth the outer co-ax conductor. It so happened that I accidentally shorted the isolating capacitor on the earthy side when the earth connection was on, with the result that I blew the fuse."

"You must have had the TV chassis connected to the live side of the mains when you did that," commented Smithy, absently. "Still never mind, boy, it could happen to anyone!"

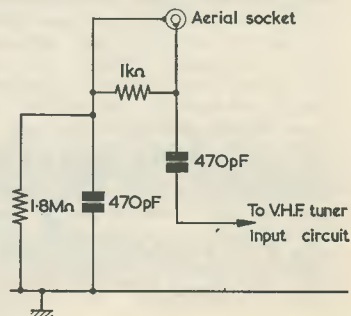

Dick swallowed, but wisely refrained from comment.

"Now this," said Smithy, peering into the TV tuner unit, "is a fault I've heard about once or twice, but have never actually encountered myself. Ah, here we are, look at this!"

Dick's eyes dutifully followed Smithy's pointing finger, to observe a small air-cored single-layer choke. One end of this had manifestly been soldered to the chassis of the tuner unit at one time, but it had now broken free.

"Is that," said Dick unbelievably, "the cause of all the trouble?"

"It is," replied Smithy with complete confidence. "Re-solder the free end of that choke to the chassis of the tuner and all the breakthrough will clear."

"Well, I'm dashed," commented Dick, still incredulous. "What on

earth made you go straight to that choke?"

"It's the obvious component," replied Smithy. "Its sole function is to prevent medium wave breakthrough."

"Then how," asked Dick, "does it work?"

"In a very simple manner," replied Smithy, "but I can't explain that without first giving you a bit of background on the type of tuner in which it is used."

Smithy took Dick's notepad and proceeded to scribble out a circuit on its top sheet. (Fig. 5 (a).)

"It's common practice these days," he said, "for the input stage of v.h.f. television tuners to have a single tuned coil only. This replaces the older r.f. transformer arrangement in which the aerial was connected to a coupling winding, which then coupled to a separate tuned coil.

The circuit I've sketched out here is typical of an aerial input stage with a single tuned coil, as it appears after the aerial isolating capacitors. C_1 and L_1 form an i.f. rejector circuit, whilst C_3 operates as a d.c. blocking capacitor. C_2 , L_2 and the input capacitance of the r.f. amplifier valve comprise a pi tuned circuit, L_2 being the tuned inductance and resonating at the selected channel. Coil L_2 is mounted on the turret itself, and so a different L_2 , tuned to the appropriate channel, is switched into circuit on each turret position selected."

"That input circuit," commented Dick, "is rather like the bottom-end aerial coupling circuit we talked about just now."

"It is rather similar," agreed Smithy. "But the turret tuner circuit has the big difference that the component values ensure accurate

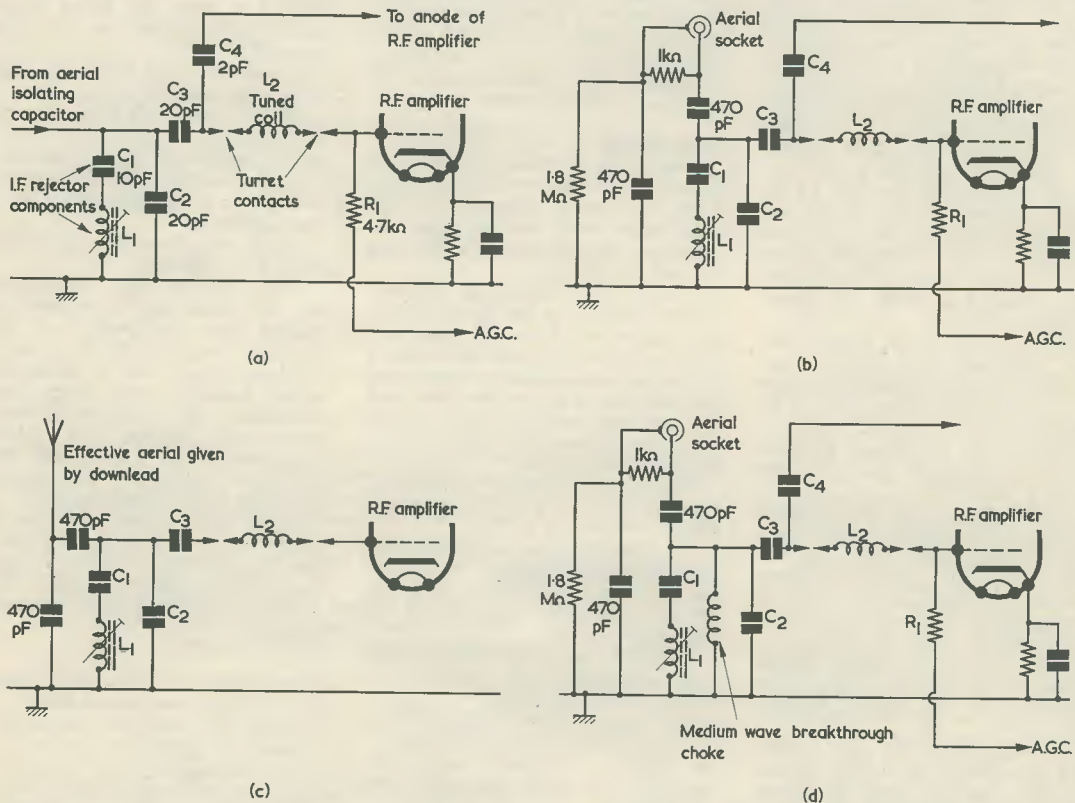

Fig. 5 (a). A pi tuned circuit in a v.h.f. tuner unit. If the r.f. amplifier is a low-capacitance triode such as the PC97, C_4 connects to its anode. If the r.f. amplifier is a cascode, C_4 connects to the anode of the first triode. Component values shown are representative

(b). Connecting the isolating circuit of Fig. 4 to the tuner input

(c). If the coaxial aerial downlead is looked upon as a single wire aerial with inner and outer conductors connected together, it becomes possible for broadcast band signals to be coupled to the r.f. amplifier grid by the circuit shown here

(d). The breakthrough given by the conditions illustrated in (c) may be prevented by adding a choke across the aerial input circuit after the 470pF isolating capacitors

matching, across C_2 , to a 75Ω input. There is a step-up effect in the circuit and it is achieved by tapping the 75Ω input into the capacitive half of the tuned circuit. This gives the same result as you'd get by tapping into the inductive half."

"What's C_4 for?"

"That," said Smithy, "is a neutralising capacitor. If the following valve is a cascode it couples to the anode of the first triode. If the following valve is one of these special v.h.f. triodes with low anode-to-grid capacitance, such as the PC97, it connects to the anode of this valve. Neutralising occurs because the end of the coil remote from the grid is 180° out of phase with the grid. Another method of neutralising consists of taking the neutralising capacitor from the remote end of the coil, and coupling this back to the grid. However, we don't want to bother about that at the moment."

"Fair enough," said Dick. "What's the next step?"

"The next step," said Smithy, "is to see what happens when we couple up the isolating capacitors and the aerial to our single winding input circuit. (Fig. 5 (b).) At first sight, everything looks quite reasonable and the circuit will, in fact, work perfectly well for the function of picking up TV signals. But there is a snag."

"There always is."

"And this snag," continued Smithy, ignoring his assistant's comment, "becomes apparent when we start to examine the coaxial download from the aerial. In most TV installations, the TV aerial will be up on the roof and there will be quite a good length of download. Apart from its function as a 75Ω feeder line, such a download can also provide an excellent aerial for broadcast signals including, in particular, those on the medium wave band."

"That's a good point," commented Dick. "If ever I want a really good aerial to check an a.m. receiver at home, I often disconnect the TV aerial from the television receiver and use it as an aerial for the a.m. set. I just connect to the outer conductor of the co-ax, and it works like a bomb!"

"It would," agreed Smithy. "Now, so far as medium wave signals are concerned, we won't, for the present discussion, be straying terribly far from the straight and narrow if we look upon the inner and outer conductors of the coaxial download as though they are connected together to form one wire. They'll

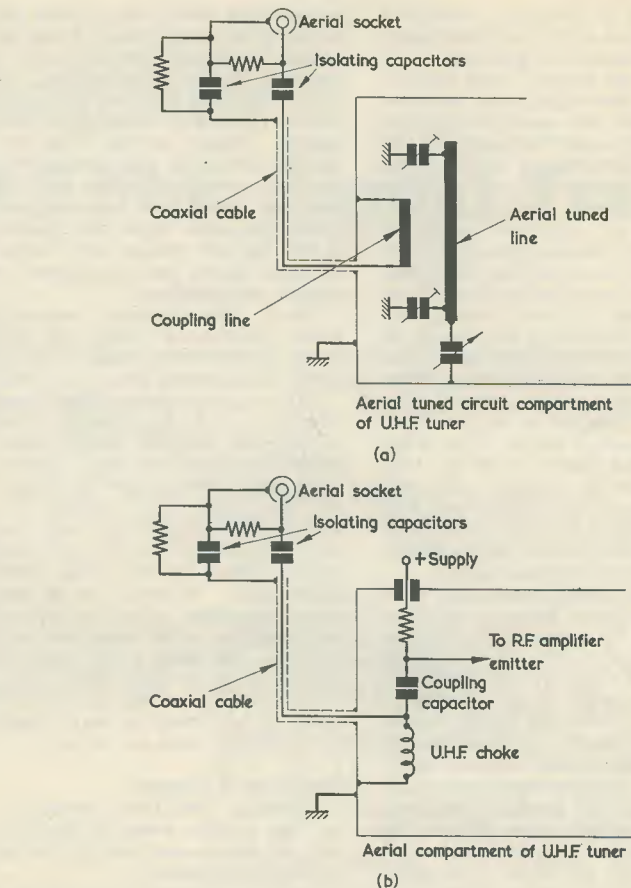

Fig. 6 (a). Medium wave breakthrough is automatically prevented in valve u.h.f. tuners because the aerial is terminated, after the isolating capacitors, in a coupling line. The components in the isolating circuit may have values roughly similar to those used for v.h.f. tuners

(b). With transistorised u.h.f. tuners having untuned aerial input stages, the aerial is terminated by a u.h.f. choke

be coupled together, in fact, by the internal self-capacitance of the coaxial cable. If the aerial is a folded dipole, there will even be, so far as medium waves is concerned, a dead short between the two conductors at the top. Let's now see what happens if we apply this effective single wire aerial to the input of our tuner."

"Blimey," commented Dick looking at the circuit Smithy was sketching out. (Fig. 5 (c).) "That's a bit different, isn't it?"

"I'll say it is," confirmed Smithy. "At the end of the effective single wire aerial we now have one 470pF isolating capacitor taking it to chassis, and a second 470pF isolating capacitor taking it to the input pi tuned circuit of the tuner. One disadvantage of a pi tuned input

circuit is that it doesn't offer a great deal of rejection to frequencies other than that at which it is resonant. It is for this reason, indeed, that the i.f. rejector components C_1 and L_1 are fitted. Our single wire aerial is bound to pick up quite a lot of signal from any local medium wave transmission. Some of this is then lost in the 470pF capacitor which connects to chassis, but the remainder will sail straight through to the grid of the valve following the pi tuned circuit. If the medium wave signal is strong enough it can run the first valve over a sufficiently non-linear part of its characteristic to cause cross-modulation. The result is that whenever you tune in a TV station you're liable to get the medium wave signal in the background in addition."

"Well, I'm dashed," exclaimed Dick. "There aren't half some queer things in this servicing racket."

"There are, indeed," said Smithy. "Now, in your experiments just now you cleared the breakthrough by earthing the outer conductor of the coaxial. However, a much easier method is to simply add to the circuit a choke having a high impedance at v.h.f. and negligible impedance at medium waves. It goes into circuit like this (Fig. 5 (d)) and it virtually short-circuits the medium wave signal without having any noticeable effect on v.h.f. signals at all. The choke will also, of course, virtually short-circuit any other strong signals that may appear in the locality, if these are in, or fairly near to, the broadcast bands. This is the choke which came adrift in that receiver you're fixing. It's not normally a critical component, and you don't need to worry if you lose a bit of a turn when you solder its end back to the chassis again."

"Do all tuners have this little choke?"

"All v.h.f. tuners with 75Ω pi input circuits have it," replied Smithy. "Or at least all those I've checked up on do. It isn't necessary, of course, with the earlier types having r.f. transformer input circuits because, apart from anything else, the aerial coupling winding in such tuners would be practically a dead short at medium waves. Some TV receivers whose v.h.f. tuners have pi input circuits are fitted with quite

complicated aerial input filter and isolating networks, these being designed to prevent breakthrough of forward scatter transmissions, i.f. harmonics from the receiver circuits and for filtering out similar unwanted signals. Despite all this extra complexity, you will still find a little medium wave filter choke after the isolating circuit, this appearing between the aerial input and chassis. If ever you get medium wave breakthrough, that's the component to suspect straightaway."

"Well, you certainly encounter some unexpected things in this game," commented Dick. "What about u.h.f. tuners?"

"There's no trouble there," said Smithy. "All the present u.h.f. tuners use circuits which automatically short out any medium wave signal which may be present. All the valve u.h.f. tuners have coupling lines (Fig. 6 (a)), and these are just an inch or two of thick copper wire at the end of the aerial input circuit. It seems that at least some transistor u.h.f. tuners are using untuned aerial stages but, even in these, the aerial input circuit is completed by a u.h.f. choke (Fig. 6 (b).) And this would spell instant death to any medium wave signal which tried to poke its way in."

The More It Changes

"There is," said Dick, ruminatively, "yet another point of similarity with the bottom-end coupling circuit we mentioned earlier."

"How come?"

"Well," said Dick, "with the bottom-end circuit you try to receive medium waves and keep the lower frequency mains voltage out. In the TV instance you try to receive v.h.f. and u.h.f. and keep the lower frequency medium waves out. And in both cases you do it by adding impedances to the aerial circuit that tend to short-circuit the frequency you don't want."

"You have," remarked Smithy, somewhat impressed, "got quite a point there."

"In other words, continued Dick airily, "*plus ça change, plus c'est la même chose.*"

Smithy sighed.

"It's no good," he grunted. "My curiosity has got the better of me. What does all that mean?"

"It means," replied Dick, "the more it changes, the more it is the same thing."

Smithy digested this information in silence.

"I must remember that one," he remarked eventually. "In the meantime I don't think I'd be stretching things too much if I said that it also applies to that poor old fuse sitting over the door there. The more you change that fuse the more it becomes the same thing."

"And what's that?"

"Blown, mate!" replied Smithy shortly. "So hurry up now and get it fixed, or that intermittent of mine will think I've given up looking for it!"

NEXT MONTH

● V.F.O. Top Band Transmitter

Simple design for the 160 metre band including a modulation amplifier suitable for use with a carbon microphone or, by employing an external amplifier, a crystal microphone.

● Infra-Red Ray Alarm System

Three versions of the alarm are given each providing faultless warning of any object passing a narrow invisible beam. Will function equally well as a burglar, fog, smoke or customer alarm.

● Sine Wave—Square Wave Converter

This unit provides a simple and cheap method of converting any sine wave voltage between wide amplitude and frequency limits into a square waveform having an extremely fast rise time and variable amplitude output.

● H_{FE} Tester for Power Transistors

Will enable H_{FE} measurements to be carried out on power transistors at high currents.

Part 2

By
P. Vernon

Beginner's A.F./R.F. Signal Tracer

In this concluding instalment of a 2-part series specially written for the beginner, constructional details of both the a.f. and the r.f. probes are described along with several simple additions that can be made to the basic circuit described last month. The uses of the complete signal tracer are also described

HAVING COMPLETED THE BASIC AMPLIFIER AND power supply described in Part 1, the next task is to construct both the a.f. and r.f. test probes for use with the amplifier. These are shown in Figs. 11 (a) and (b).

A.F. Test Probe

Reference to Fig. 11 (a) will show that the a.f. test probe is simply a length of coaxial cable, some

Components List (Fig. 11 (a))

Capacitor

C₇ 0.1 μ F, tubular 350V wkg.

Miscellaneous

Coaxial cable (75 Ω), Coaxial Plug, probe

(Fig. 11 (b))

Resistors

(All $\frac{1}{4}$ watt-10%)

R₇ 270k Ω

R₈ 47k Ω

Tagstrips

4-way, end tags earthed, 2 required

Miscellaneous

2-oz tobacco tin; Coaxial cable (75 Ω); Rubber Grommets (2 $\frac{3}{8}$ in, 1 $\frac{1}{4}$ in); Coaxial plug; nuts & bolts, solder, Crocodile clip, wire, etc.

Capacitors

C₈ 100pF, silver mica or ceramic, 350V wkg.

C₉ 100pF, silver mica or ceramic

C₁₀ 0.02 μ F, tubular (Mullard)

Diode

D₁ OA91 (Mullard)

Probes

Type TP25 (A. F. Bulgin Ltd.) (see text)

18in being sufficient in most cases, in which is inserted the capacitor C₇; the cable being terminated at one end by a test probe and at the other by a coaxial plug.

The capacitor C₇ is connected, in series with the centre conductor of the coaxial cable at the probe itself. The braiding of the cable terminates just before the connection to the capacitor, there being no connection to it at the probe end.

The test probe can either be made from a discarded ball-point pen casing or purchased new (Cat. No. TP25/Red or TP25/Black, Home Radio (Mitcham) Ltd. at 3s. each, postage 1s. 6d.).

Having soldered one end of C₇ to the inner lead of the coaxial cable, the other end of this component should be secured to the test probe.

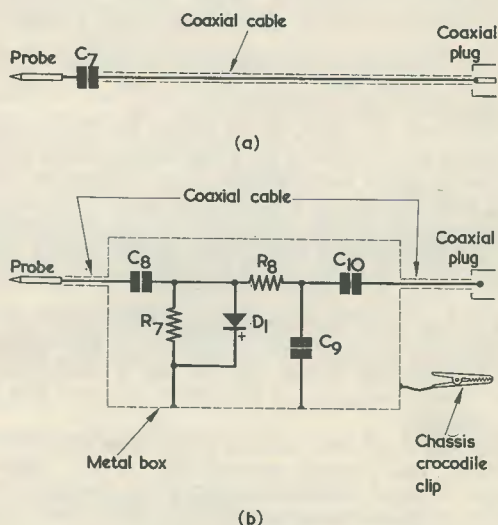

Fig. 11 (a). The a.f. test probe
(b). Circuit of the r.f. test probe unit constructed in a 2-oz tobacco tin. There is no connection to the coaxial cable braiding at the probe end of the input lead

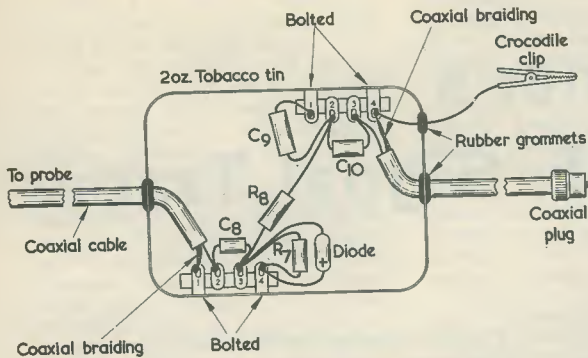

Fig. 12. Point-to-point wiring diagram of the r.f. test probe unit

The capacitor is then covered with insulating tape which is wound such that the tape extends from the test probe body to the outer covering of the coaxial cable. The free end of the coaxial cable should now be secured to the plug, ensuring that the outer metal braiding of the cable makes a good contact with the outer conductor of the plug.

R.F. Test Probe

Fig. 11 (b) shows the circuit of the r.f. test probe which is, in fact, a simple untuned detector stage.

With the probe connected to a source of r.f., coupling is made via C_8 to the shunt detector diode D_1 . The detected a.f. appearing across this diode then passes through the r.f. filter R_8 , C_9 before being applied, via the coupling capacitor C_{10} , to the amplifier.

It will be noted that the unit is fitted with a flying lead terminated in a crocodile clip, this being required to connect to the chassis of the unit under test.

Fig. 12 shows the point-to-point layout of the r.f. test probe unit and this, as may be seen, is constructed within a 2-oz tobacco tin.

The first task here is to secure the two 4-way tagstrips to the sides of the tin as shown, these being bolted at tags 1 and 4 in each case. Following this, two holes should be made in the ends of the tin of sufficient size to take $\frac{3}{8}$ in rubber grommets through which the coaxial input and output cables will pass; also a hole for the flying lead, which requires a $\frac{1}{2}$ in grommet.

Dealing with the lower tagstrip first, to tag 1 solder the outer metal braiding of the coaxial cable from the probe and to tag 2 solder both the inner conductor of the cable and one end of C_8 (100pF).

To tag 3 of the tagstrip solder one end of R_7 (270kΩ red, violet, yellow) R_8 (47kΩ yellow, violet, orange), the free end of C_8 and the diode D_1 . When making these connections, first insert and make mechanically secure the wire ends of R_7 , R_8 and C_8 to tag 3 and then insert the wire end of D_1 , holding the wire of the diode in position with a pair of pliers to form a heat shunt whilst applying the soldering iron.

To tag 4 connect the free ends of both R_7 and the positive end of the diode D_1 —again using a heat shunt with this latter component whilst soldering.

Turning to the top tagstrip, to tag 1 solder one end of C_9 (100pF).

To tag 2 of the tagstrip secure and solder the free ends of C_9 , R_8 , and one end of C_{10} (0.02μF).

To tag 3 solder the free end of C_{10} and the inner conductor of the output coaxial cable.

To tag 4 of the tagstrip secure the outer metal braiding of the coaxial cable and one end of a length of flexible p.v.c. covered wire. The flying lead to the crocodile clip and both lengths of coaxial cable should all be about 12in in length.

Pass both lengths of coaxial cable through the respective rubber grommets, terminating the input lead with a test probe and the output lead with a coaxial plug—ensuring in the latter case that the outer metal braiding makes good contact at the plug. Feed the flying lead through its rubber grommet and fit a crocodile clip.

Once completed, the tin should be given two coats of paint, having firstly rubbed down the outer face of the tin with emery paper in order that the paint will "grip" the surface.

Additions to the Amplifier

Two refinements can be made to the basic circuit of the amplifier/power supply shown in Fig. 1 published last month. The first of these is a tone control giving some measure of top cut when using the unit as an amplifier. This is shown in Fig. 13 and will be seen to consist quite simply of an additional capacitor which should have a value of 0.1μF and a working voltage of 500, a 50kΩ potentiometer and a 2.2kΩ fixed resistor.

The capacitor should be connected between the anode of V_2 (pin 3) and one end of the potentiometer, the centre slider of which is connected to chassis via the 2.2kΩ resistor. The potentiometer should be mounted on the front panel at a point midway between R_1 and $S_{1(a),(b)}$ —see Fig. 2 (b) published last month.

The second addition is one that provides a

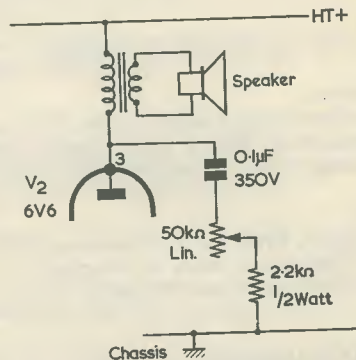

Fig. 13. Circuit of the added tone control connected between the anode of V_2 (pin 3) and chassis. The capacitor should have a working voltage rating of 500

visual indication of whether the power supply is connected to the amplifier section or to an external unit, and this may be done in either of two ways according to individual preference, see Fig. 14.

In the more simple method, a panel mounted indicator assembly complete with a 6.3V 0.3A bulb, should be connected between tag 3 of the switch $S_{1(b)}$ —see Fig. 4 published last month—and chassis. Twisted p.v.c. covered wire should be used for these connections and a small rubber grommet will be required to take the two leads through the chassis deck to the assembly. Some indicator assemblies have one tag common to the mounting bush—ensure that the lead from tag 3 of the switch does *not* connect to such a tag.

With this modification, when the amplifier is in use, i.e. with switch $S_{1(a),(b)}$ in the closed position, the indicator assembly will light up and, conversely, will go out when the unit is used as a power supply for an external unit.

The second method, which is really an addition to the foregoing, is to carry out the modification already described and connect into circuit an additional panel mounted assembly between tag 4 of the switch $S_{1(a),(b)}$ and the chassis. With this method, one panel assembly could be coloured red and the other green. When the amplifier is in use, both assemblies will light up and when used with an external unit only one will light, thereby giving a visual indication at all times.

Using the Unit

Assuming a receiver has been constructed and requires testing, or exhibits a fault, the following is the procedure to be adopted using the units described in this article.

Inject a signal into the aerial socket of the receiver by connecting the aerial and tuning in a station on, say, the medium waves (if this is possible with the receiver at fault). Connect the r.f. probe to the amplifier input and the flying lead to the receiver chassis. Turn R_1 of the amplifier up to maximum. Assuming the first stage of the receiver to be an r.f. amplifier, place the r.f. probe on the grid of the r.f. valve and, if this was not possible in the first instance, tune in a station. If no signal can be heard, this would indicate that the fault exists at a point in the circuit between the aerial input and the grid of the valve, (coils and bandswitch).

Should, however, all be well up to this point, remove the probe from the grid of the r.f. valve and place it on the anode of the same valve. The

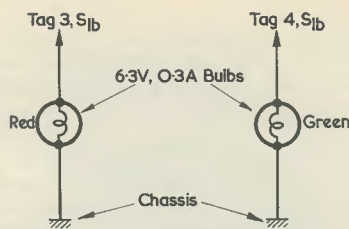

Fig. 14. Circuit of the added indicator bulbs. One or both may be added as desired—see text

signal strength should increase owing to the r.f. amplification of the stage. If not, then there is something wrong with this stage, i.e., too little or no h.t. potential on the anode or screen grid; cathode resistor or bypass capacitor faulty or valve faulty. In the above manner the faulty stage(s) may be isolated.

If the receiver is a superhet, place the r.f. probe on the grid of the frequency changer and check as above for the r.f. stage. If a signal is heard from the amplifier speaker, transfer the probe to the frequency changer anode. Then proceed to the i.f. amplifier grid and anode, checking for loss of signal or lack of amplification at any anode relative to its grid.

If no fault has yet been found, remove the r.f. probe from the amplifier, insert the a.f. test probe and connect the amplifier and receiver chassis together by means of a length of wire terminated at each end with a crocodile clip.

Use the a.f. probe from the audio gain control to the anode of the output valve at the points in the circuit where a.f. is (or should be) present.

In the above manner both receivers and amplifiers may be tested for r.f. or a.f. signals, some interesting comparisons being made between grids/anodes and various stages, and some lessons learned.

Note. The unit described in this short series should not be used by beginners for testing any mains operated receivers or amplifiers having chassis which are connected to one side of the mains supply, as occurs, for instance, with equipment having a.c./d.c. power supplies. Coupling the signal tracer to such chassis results in its own chassis and metal-work becoming similarly "live" and there is a high risk of shock in consequence which can be particularly dangerous with the more inexperienced. The tests described above have assumed valve receivers for ease of explanation, but they may also be applied to transistor receivers.

COMPACT SILICON BRIDGE RECTIFIER

Complementary to the recently introduced Mullard harmonious range of audio transistors is a new silicon bridge rectifier assembly for use in the power supply sections of mains-operated radiograms, record players and tape recorders.

The rectifier assembly, type BY122, is rated for an r.m.s. input voltage of 42V and gives a rectified output of up to 50V at a current of 0.5A.

It measures only 12 x 10 x 7 mm. and has an insulated plastic encapsulation. Four lead out wires are fitted.

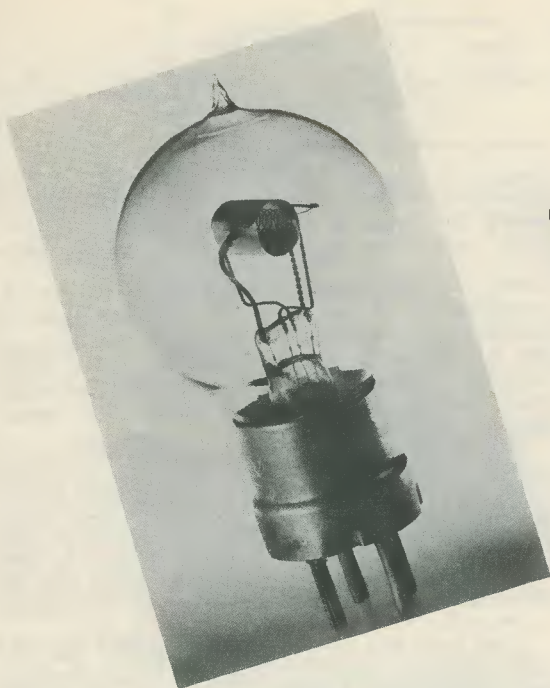

The Story of the Valve

Part I

C. H. Gardner

As readers who followed his series of articles "Experiences Of An Early Amateur" (in the August to December 1964 issues) will already know, C. H. Gardner has played a colourful and individual part in the development of radio in this country

Once again he takes a look at the earlier days, but in this instance it is to relate the progress and development of the valve from its inception to its present status in electronics. This is a journey in time which is intimately bound up with the technicalities of valve production, a subject which

C. H. Gardner, with his long association with Mullard Ltd., is especially fitted to discuss. In this article, the first of a 4-part series, the valve comes into being as a practical communications tool, and we trace it through to the first days of mass production. The succeeding articles carry the tale up to the present day, working always from the viewpoint of the engineer. It is impossible to fully appreciate the working of a device without examining the developments which have brought it to its present design condition. This point is amply demonstrated in "The Story Of The Valve"

FEW THINGS HAVE MADE A GREATER CONTRIBUTION to the general welfare of mankind than the invention and development of the electronic valve. It is difficult to imagine the chaos that would result in the world if for some reason valves suddenly ceased to operate. Yet it is only sixty years since the very first primitive valves were made, and not a great deal over thirty since they came into everyday use in their simplest form.

As is the case with many important inventions, the birth of the valve was the result of intelligent observation of phenomena not immediately concerned with eventual applications. It occurred when Edison, engaged in work on the development of the electric lamp, realised that an electric current could only be made to pass in one direction between a heated filament and an additional electrode contained in an evacuated bulb. The discovery of a possible application to radio must be credited

to Fleming, although he was under the impression that the current was carried by atoms of carbon from the filament. This impression was corrected in 1889 by J. J. Thomson, who found that the current was due to emission of electrons from the heated filament.

Patent For A Rectifier

Fleming, who had been one of Maxwell's pupils, had been interested in electromagnetic waves ever since the Maxwell Equations had been produced. He duplicated Hertz's experiments of 1887-88. His interest in wireless telegraphy dated from 1896-97 when it became known that Marconi had succeeded in establishing ranges of several miles. Fleming became Scientific Adviser to the Marconi Co. in 1899, but continued his duties as a lecturer.¹

¹ Ambrose Fleming continued to lecture until he was 90 years of age—see News and Comment, page 314, December 1964 issue.
—EDITOR.

It was not until 1904 that he realised that the electron emission effect could be used as a method of rectifying alternating currents and, as a result, took out a patent to cover the matter. In this patent he describes the construction of a valve with a filament heated by a battery and surrounded by a metal cylinder to which external connection could be made by means of a wire passing through the bulb. His patent covered the use of such a valve as a rectifier. He also mentioned the possibility of producing electrical oscillations by employing two valves working in opposition. It is interesting to note that Wehnelt discovered in the same year that greater emission could be obtained at a lower temperature by coating the filament with various oxides.

Two years later Lee de Forest put the third electrode, the grid, in the valve; but it is quite astonishing to find that many further years had to pass before either the two or three electrode valve was adopted to any appreciable extent by the makers of wireless telegraphy equipment.

The reasons for delay were many. With the type of equipment available in the pre-1914 era, sensitivity of the "detector" was a vital matter. At that time, the Rutherford magnetic detector was in common use. It was a highly reliable but somewhat insensitive piece of apparatus, and was gradually being replaced by the crystal detector. The latter varied in sensitivity with the combination of crystals used and, unfortunately, the most sensitive combinations were not the most reliable in service. Nevertheless, even the less sensitive types proved to be more sensitive than the valve rectifiers which were available in that period.

Another probable cause of delay was the considerable and lengthy litigation taking place in regard to the validity of some of the patents involved. The Fleming Patent was owned by the Marconi Company and, as the U.S.A. courts decided that de Forest could not make triode valves without infringing Marconi patents and that Marconi could not make them without infringing de Forest patents, an impasse was presented which did not resolve itself until well after the termination of the First World War.

It is also true that, in the pre-1914 era, the technique of producing a really hard vacuum in the valve had not been mastered. In fact some of the early rectifiers relied for their operation on the presence of a certain amount of gas which had to be produced by heating an asbestos pellet. When a triode was used for rectification no grid leak was used or was even necessary. The use of a triode as a rectifier came about largely as the result of work carried out by E. H. Armstrong, who obtained a much harder vacuum for his experimental valves by using methods evolved by Langmuir.

War Developments

In the meantime Round and Franklin had been carrying out experimental work which resulted in the discovery of reaction and the use of the valve

as an oscillator for heterodyne reception. They also encountered the necessity of reducing the inter-electrode capacitance of the valve in order to obtain effective results from several stages of r.f. amplification.

Thus, at the start of the 1914 war, there was a little knowledge of some of the fundamentals of valve design; and the war itself speeded up research work sufficiently to enable a few valves to be produced for service purposes. This resulted in the early production in France of the well known "French R type" a hard triode valve with a horizontal tungsten filament surrounded by a spiral grid, the whole being enclosed in a cylindrical anode. The connections were brought out to four pins in a moulded base, and the pinning arrangement adopted remained standard for battery triodes for nearly thirty years. The electrode system was held in place by connecting wires which were welded into a glass "pinch" similar to that used in electric light bulbs. Some work was also done to improve the life of the vacuum in the bulb by degassing the electrodes. This type of valve, with the rather peculiar filament rating of 3.7 volts, 0.5 amps, was the first to become available to the amateur at the termination of the war. It appeared in the first place through war disposals and, later, through imports and our own manufacturers.

Due to the intensive experimental work undertaken during the war a great deal more was learnt about the actual working of the valve, together

² Another important aspect was the discovery of the valve's ability to act as a generator of c.w. oscillations, thus opening the door to radio-telephony, broadcasting, etc. This discovery was made by several people almost simultaneously—Meissner, Armstrong, de Forest, Langmuir, and Round—in 1913.—EDITOR.

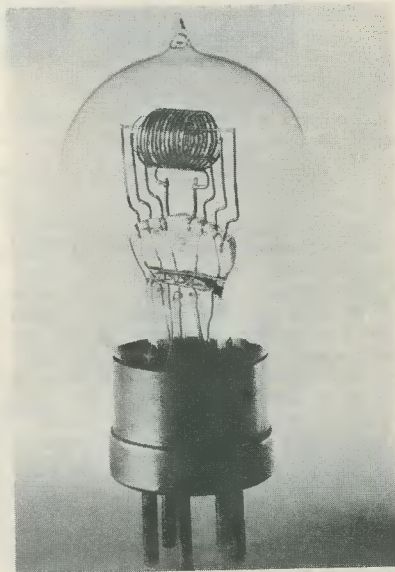

An example of the Mullard ORA valve, which appeared on the radio scene in the very early 1920's. The electrode supports are held in the glass "pinch". Another Mullard ORA valve is shown in the heading illustration

with matters of design and production to improve its performance and life. As a result, it became possible to produce valves with finer tolerances, and to introduce types suitable for specific applications. The technical cynic of today is sometimes apt to suggest that all the valves produced at that time were meant to be identical but that they were sorted out and marked in their various types after test.

Quantity Production

Be that as it may, the valve had reached the stage of small quantity production and some degree of standardisation. The immense possibilities opened out by its use in wireless communications were becoming apparent. By the early 1920's, manufacturers were able to commence producing simple triodes in much larger quantities than before, and with a reasonable certitude that they would be required as standard equipment in receivers and amplifiers.

The manufacture of such valves required many new types of plant and machinery as numerous new principles were involved. The valve required a much harder vacuum than the electric light bulb, and some method had to be found of retaining that vacuum whilst the valve was in use despite the release of gases occluded in its various components. Machinery had to be designed for the quantity production of the electrodes, and experi-

ments made in connection with the oxide coating of the filaments.

It was during this period of immense trial and error that broadcasting commenced, with the result that manufacturers were receiving ever-increasing demands necessitating "mass production" methods. At the same time, technical development was so rapid that any such methods must perforce be of a nature which would enable modifications to be carried out without having to scrap expensive plant.

From this time on development progressed along three distinct lines. The need for sensitivity as well as selectivity required research into valves having improved performances. The number of broadcast transmitters and receivers continually increased, necessitating intensive engineering research work into the production of valves in quantities approaching the hundreds of thousands. Thirdly, it was essential to develop and produce more efficient and more reliable valves. To describe in full detail the progression of these lines of research would be impossible in a short series of articles, and those which follow will deal with the major developments which have led to this country alone producing each year more than sixty million valves of an efficiency and reliability undreamt of forty years ago. In those days it was not unknown for customers to queue up outside the valve factory door to get their share of the day's production of a few dozen valves.

(To be continued)

Measuring Oscilloscope Input Voltage

by H. T. KITCHEN

An ingenious approach to the problem of measuring input waveform amplitude

MOST OSCILLOSCOPES, WHETHER home or factory made, have no means of measuring, with any degree of accuracy, the input signal to the Y amplifier. Some, it is true, have a graticule which, in conjunction with a calibrating voltage (usually 50 c/s derived from the heater line and sometimes squared) enables a rough check to be made of the input voltage. The author has at some time or other built oscilloscopes from 1in upwards, and with Y amplifiers and timebases of differing degrees of complexity, but all were without a means of measuring the input voltage directly. The circuits to be described are the outcome of much thought and some experiment aimed at alleviating this disadvantage.

Measuring Y Deflection

Fig. 1 shows a typical Y output stage feeding a c.r.t., and is most commonly used in amateur circuits. The anode of the output valve is directly coupled to one Y plate, whilst the other Y plate connects to the wiper of the 250k Ω potentiometer. Adjustment of this potentiometer causes the direct voltage on the Y plate to be varied relative to the direct voltage on the other Y plate, thereby causing the trace to be moved up or down. This is the Y shift control. If it has sufficient range to enable first the positive and then the negative peak of a displayed waveform to be placed so that they, in turn, just touch the centre line of the graticule, it offers a convenient means of measuring the peak-to-peak

voltage of the displayed waveform. The circuit of Fig. 2 enables this to be done.

In Fig. 2 the two triodes V_{1(a)} and V_{1(b)} form a balanced valve voltmeter in which an alteration to the direct voltage on either grid will cause a deflection in the meter. R₅ has been previously set, as is explained later, to enable the milliammeter to indicate voltage.

The left hand triode grid is connected to the wiper of the Y shift control via the 1M Ω resistor R₁. One of the peaks of the displayed waveform is brought to the centre line of the graticule by means of the Y shift control. The meter is then brought to zero by means of the "Set Zero" control, R₇. The Y shift control is again operated to bring

the other peak of the displayed waveform to the centre line of the graticule. The meter will now read the peak-to-peak voltage of the displayed waveform.¹

Fig. 3 shows the push-pull Y output stage associated with the better types of oscilloscope and is to be preferred, with some exceptions, to the single-ended type. Although the metering circuit of Fig. 2 could be used with the push-pull output stage by connecting it, as before, to the wiper of the Y shift control, it is preferable to use the circuit of Fig. 4. This not only employs fewer components but is much more convenient to use. It is basically similar to the previous circuit and, indeed, to the push-pull amplifier of the oscilloscope. The two grids are connected to the anodes of the push-pull amplifier and a centre-zero meter is used, again with a suitable series resistor which has previously been set up.

To measure the displayed voltage it is only necessary to zero one peak to the graticule centre and then the other peak, noting the meter deflections both ways. The peak-to-peak voltage is the sum of both meter deflections.

Components in the Prototype

Although the recommended components in Figs. 2 and 4 should be used whenever possible, alternative valves and meters should work quite well, with possible changes in the anode load and cathode bias departments. A double-triode is preferable to two single triodes since any change in characteristics is more likely to affect both triodes equally. The anode and grid resistors should, preferably, be within 5% of each other in Fig. 2. In Fig. 4, only the grid resistors need be within 5%.

Capacitors having a value of $0.1\mu\text{F}$ are used in the grid circuits of Figs. 2 and 4, but any value from 0.05 to $1\mu\text{F}$ should prove suitable. These capacitors serve to bypass any extraneous noise that might cause the meter needle to jump about at random.

A 1mA meter was employed in the prototype because it was to hand, but the author sees no reason why meters from $50\mu\text{A}$ to some 5mA should not be used instead, with obvious changes in the series resistors.

¹ According to the design of the oscilloscope, either the upper or the lower peak will have to be centralised first. Commencing a measurement with the wrong peak centralised will, of course, result in the meter giving a reversed reading.—EDITOR.

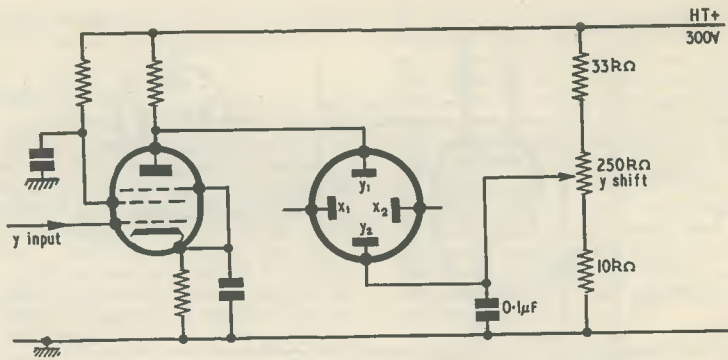

Fig. 1. A commonly encountered circuit for Y shift and deflection

Construction

Construction is quite simple and can take one of two forms, internal or external. Where space can be found on the front panel of the oscilloscope, internal mounting is to be preferred, since it is both neater and more convenient. Lacking panel space, the meter and valve could be built into a small box or case, a standard $6 \times 4 \times 2\frac{1}{4}$ in aluminium chassis being ideal. A suitable layout is given in Fig. 5.

The case can be connected to the oscilloscope via a 5-pin non-reversible plug and socket and, of course, a sufficient length of cable. The connections needed for the Fig. 2 circuit are: chassis, h.t. positive, heater, and Y shift control wiper. For the Fig. 4 circuit they are: chassis, h.t. positive, heater, and the two Y plates.²

Calibration

Before describing the actual process of calibration, it is first necessary

² To prevent applying excessive stray capacitances across the Y plates, the $1\text{M}\Omega$ resistors in Fig. 4 (R_1 and R_6) could be mounted, inside the oscilloscope, at or near the base of the cathode ray tube.—EDITOR.

to explain that two methods or types of voltage calibration are possible. What we do during calibration is to measure the peak-to-peak voltage on the screen of the oscilloscope, and peak-to-peak voltages are nearly always used in oscilloscope measurement. However, an accurately metered alternating voltage is necessary for the calibration process, and this will almost certainly have been measured by a meter responding to r.m.s. values. The result is that if the oscilloscope meter is going to be calibrated in peak-to-peak voltages, conversions from r.m.s. will have to be carried out during calibration. For subsequent measurements, conversions from peak-to-peak to r.m.s. may also be needed. Since the sensitivities of such important items as tuners, pick-ups, amplifiers, microphones, etc., are nearly always given in r.m.s. values it may well be easier and simpler to calibrate the meter using r.m.s. values only. The choice is left to the discretion of the individual.

Calibration is quite simple in practice and should be delayed until both the oscilloscope and the meter valve have had adequate time to

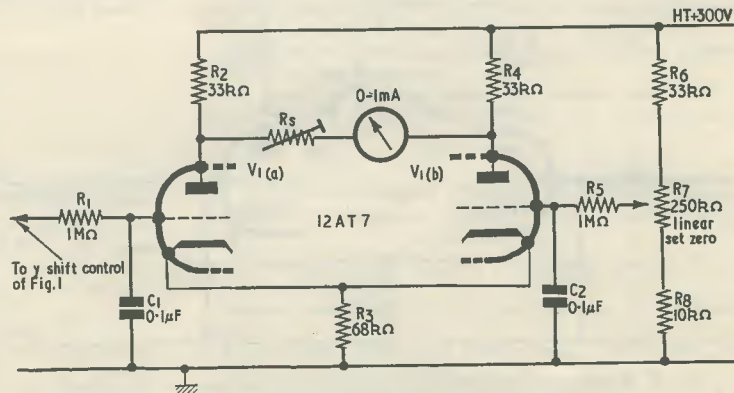

Fig. 2. A meter circuit suitable for coupling to Fig. 1

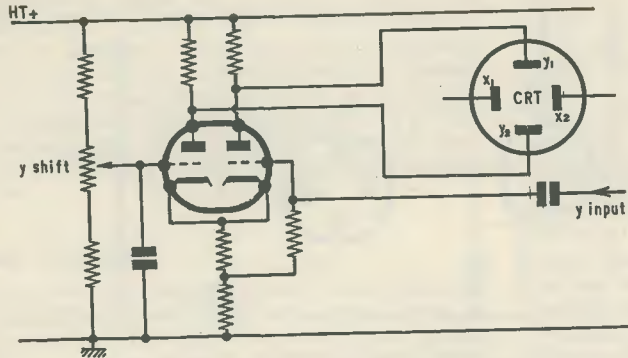

Fig. 3. Push-pull deflection, with Y shift control

warm up. An accurately metered voltage is then fed into the Y terminal of the oscilloscope and the timebase adjusted until some 10 to 15 cycles are displayed. The more cycles displayed the easier it is to set the positive and negative peaks to the graticule centre line. The oscilloscope should either be at its most sensitive or else have a known amount of attenuation introduced.

If the arrangement of Fig. 2 is being calibrated, the oscilloscope and meter controls are adjusted as previously described so that first one peak and then the other is against the datum line. The series resistor, R_s , is then adjusted until the meter reads one of two voltages, these being peak-to-peak or r.m.s. as desired. Once set, the series meter resistance will not need altering unless a valve or other component is changed.

The circuit of Fig. 4 requires a rather different approach. After the warming-up period the trace of the oscilloscope is set to the graticule

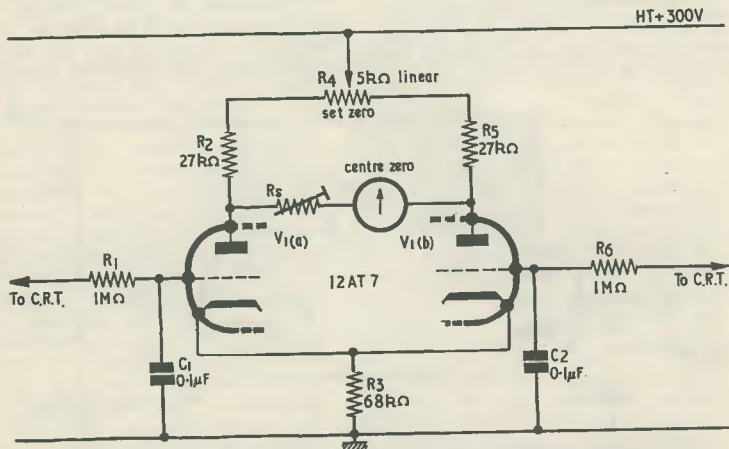

Fig. 4. A meter circuit which may be coupled to an oscilloscope having push-pull deflection. R_1 and R_6 connect to the Y plates of the tube

centre line with no Y input. If the pointer of the centre zero meter is off centre, it should now be centred using the Set Zero control R_4 . A known voltage is then applied and the oscilloscope Y shift control operated to place the positive peak precisely on the centre line. The series resistor is now adjusted to bring the meter pointer to half the input voltage. The negative peak is next placed on the centre line by means of the Y shift control, whereupon the meter should read an identical voltage on the other side of zero. The voltage input is then the sum of the two meter readings. A short cut with symmetrical traces is

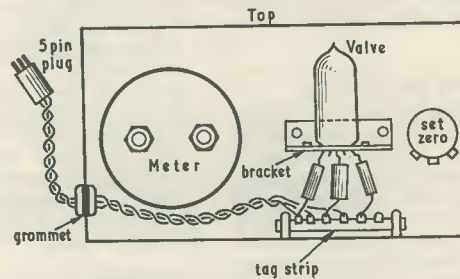
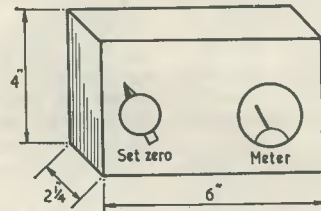

Fig. 5 (a). Front view of an external meter case, illustrating suitable dimensions and layout
(b). Rear view, showing some of the internal components

to measure one peak only and multiply by two.

There is one type of Y amplifier that, in its existing form, is unsuitable for use with the meter. This is the circuit in which Y gain is continuously variable, making the relating of input to displayed voltages impossible. However, for a.f. work, excluding square waves, a simple resistive step attenuator could be substituted. It must be pointed out, and always borne in mind, that the meter reading will have to be multiplied by any attenuation found necessary at the "front end" of the oscilloscope. Failure to do so could cause misleading results to be obtained.

Component Values

The component values shown in Figs. 2 and 4 are correct for the

author's oscilloscope but may require altering to suit different conditions and components. The cathode bias resistors, particularly, may require altering in value, and should be adjusted, if necessary, to keep the cathode voltage some 2.5 to 5 volts more positive than the grid. If the grid is allowed to go more positive than the cathode, rapid destruction of the valve can be expected. The question of bias resistors is discussed further under "Final Points".

The series resistor, R_s , will depend on the meter, 100k Ω linear being suitable for a 50 μ A and 5k Ω linear for a 1mA movement. However, the deflection sensitivity of the oscilloscope must also be considered, and the final f.s.d. of the

meter arranged so that windowing or clipping of the trace is avoided.

Final Points

It will be appreciated that this article is partly of an experimental nature because it is impossible to foresee the exact circuit values needed for all possible conditions. Nevertheless, the experienced amateur who has grasped the basic principles and is prepared to experiment should be able, from the information given, to build a metering unit which suits his own particular needs.

To give further guidance it can be stated that there are two ways of providing the correct value of bias

for the meter valve if grid voltages are liable to be high. One, consisting of increasing the value of the cathode bias resistor, can only be carried so far. The other way is to provide a high value potential divider between the oscilloscope output stage and meter valve to reduce the potential on the grid to a suitable level. If the "top" resistor of such a potential divider has a high value and is connected close to the output valve anodes or c.r.t. base, it will have a minimal effect on the operation of the oscilloscope.

Carefully constructed, accurately calibrated and intelligently used, this measuring unit will prove to be a most useful addition to any oscilloscope.

Club Events

North West V.H.F. Group

The 1965 North West V.H.F./U.H.F. Convention and Dinner will be held at the Grosvenor Hotel, Deansgate, Manchester, on Saturday, 18th September, from 13.30 hrs. onwards, Convention Dinner at 19.30 hrs.

A programme of visits to establishments of electronic or radio interest is being organised and visitors will be asked to state a preference upon "booking-in". Mrs. J. Stace G3CCH and G3LTF will give a talk on their Meteor Scatter and Moonbounce activities together with recordings. A film show, exhibition by the trade, competition for the best unit of amateur built equipment, raffle, etc., will be among features of interest. YL's and XYL's welcome.

The Convention station operating on 144 Mc/s under G3UHF/A will be on the air from early morning, with a /P station on high ground to the south, contacting distant mobiles.

Overnight accommodation at the Grosvenor or alternative hotels is available at slightly reduced charges. Requests for tickets to the Convention and Dinner at 25s. each, or hotel reservations should be made to T. Davison, G3AGS, 18 Boardman Road, Higher Crumpsall, Manchester 8, Tel.: Cheetham Hill 2762. All other information from G. Barnes G3AOS, 5 Prospect Drive, Hale Barns, Cheshire, Tel.: Ringway 2415.

The Slade Radio Society

Secretary: D. Wilson, 177 Dower Road, Sutton Coldfield.

September 3rd—Radio Teleprinting, lecture by G. Sykes followed by demonstration arranged by J. Hartwell.

September 17th—The Y of My Hi-Fi, member Dr. Williams discusses and demonstrates his sound reproducing equipment.

September 19th—R.S.G.B. final D.F. test.

Slow Morse practice and constructional projects every Wednesday evening at the Club station—The Church House, High Street, Erdington, all meetings commence 7.45 p.m.

Derby and District Amateur Radio Society

Secretary: F. C. Ward, 5 Uplands Avenue, Littleover, Derby.

September 4th and 5th—V.H.F. National Field Day.

September 8th—Technical Film Show, M. Shardlow and J. Anthony.

September 11th—Twelfth Symposium on Amateur Radio at the Residential Youth Centre, Ollerton, Newark, Notts. At the symposium—in the heart of Sherwood Forest, Nottinghamshire—there will be a special station operated by the Magnus Radio Society assisted by the Mount School Radio Society. "Robin Hood" (GB3RH) will operate on 160m, 80m and 20m. A special QSL card will be issued to confirm all contacts. Reports which will be greatly appreciated should be sent to G3PAW, Magnus Grammar School, Newark, Notts., or the R.S.G.B. QSL Bureau.

September 15th—D.F. Practice Night. Social evening for non-participants.

September 19th—R.S.G.B. National D.F. Final in Derby; organisers A. Hitchcock and F. Allsopp.

September 21st—Heanor and District Radio Society Social Evening at Heanor Technical College.

September 22nd—Magazine Production, R. E. Street.

September 24th—R.S.G.B. Region 4, Lecture 1 at Lecture Theatre, Derby and District College of Technology, Kedleston Road, admission by ticket only.

September 29th—Applications of Glass Fibre, demonstration by A. Hitchcock.

All meetings (unless otherwise stated) are held in Room 4, 119 Green Lane, Derby, and commence at 7.30 p.m.

Northern Heights Amateur Radio Society

Secretary: A. Robinson G3MDW, Candy Cabin, Ogden, Halifax

September 15th—Further S.S.B. Comments by A. W. Walmsley G3ADQ.

September 29th—The G2DAF Receiver by J. Peevors G3NFH.

September 30th—Visit to the Spen Valley Radio Club for a talk on propagation.

All meetings (unless otherwise announced) are held at the Sportsman Inn, Ogden, Halifax, at 7.30 p.m.

IN LAST MONTH'S ARTICLE WE INTRODUCED THE triode, showing that the insertion of a grid between the cathode and the anode makes this valve capable of offering amplification of an alternating voltage applied to the grid. We then considered the situation which arises when two triode valves are coupled together by way of a capacitor so that the second amplifies the output from the first. We finally dealt with bias circuits, including that required for cathode bias.

We shall now consider some of the basic circuits in which a triode may be employed.

Driving a Loudspeaker

The alternating voltage amplified by a triode valve is frequently an audio frequency voltage. We saw a typical instance of this application last month in Fig. 303 (b), which showed a carbon microphone coupled to the grid of a triode. When an audio frequency voltage is applied to a triode, or to several triodes in cascade, we will, for normal

anode circuit, the value of this load impedance depending upon the valve type employed. The optimum load impedance is listed in the manufacturer's technical information on the valve, in which the term "load impedance" may be abbreviated to R_a (it being assumed that the impedance is resistive). Let us assume that, in the present example, we shall employ a triode which requires an anode load impedance of $5k\Omega$. At the same time, the loudspeaker we shall use with the triode is a moving-coil type having an impedance of 3Ω . No great problem is involved in coupling the loudspeaker to the valve, and all we need is a step-down transformer whose ratio is such that the impedance presented by the primary is the $5k\Omega$ required by the valve. The transformer is connected as shown in Fig. 309.

understanding

BASIC VALVE CIRCUITS

By W. G. Morley

applications, require that the amplified signal be reproduced in a form which can be perceived by the ear. An obvious device for this purpose is the loudspeaker.¹

It is quite possible for a triode valve to drive a loudspeaker but it is necessary to ensure that the impedance presented to the triode anode is such that a satisfactory amount of power is fed to the loudspeaker. This is rather a different concept from the voltage amplifier we considered last month, because the latter was only required to provide an alternating voltage across a resistor. In the present instance we require that a significant amount of *power* be applied to the loudspeaker, and we refer to the amplifying valve as a *power amplifying* valve in consequence.

For reasons which we shall examine in a later article, a power amplifier valve offers best performance in terms of efficiency and low distortion when a particular load impedance appears in its

¹ Loudspeakers were discussed in detail in "Understanding Radio" in the issues for May to December 1964 inclusive.



radio

As we have learned earlier², the impedance presented by the primary of the transformer in Fig. 309 will be equal to the secondary load impedance (the 3Ω of the loudspeaker) multiplied by the square of the primary-to-secondary turns ratio. If we call this ratio N , then

$$Z_p = N^2 Z_s$$

Rearranging the equation to bring N over to the left hand side, we get

$$N^2 = \frac{Z_p}{Z_s}$$

$$\therefore N = \sqrt{\frac{Z_p}{Z_s}}$$

Whereupon, we may see that the ratio is the square root of the required primary impedance divided by the secondary impedance. In our present example the required primary impedance is $5k\Omega$, or $5,000\Omega$,

² In "Understanding Radio" in the July 1963 issue.

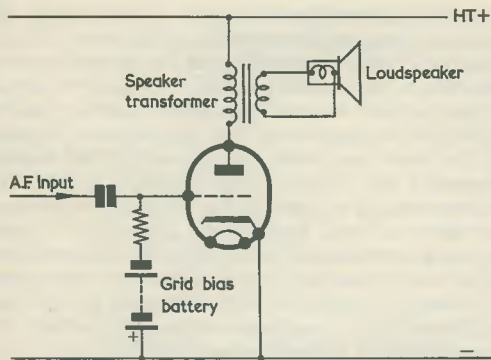

Fig. 309. Coupling a triode power amplifying valve to a loudspeaker by way of a speaker transformer. A grid bias battery is shown, but cathode bias could be employed just as readily

and the secondary impedance is 3Ω . So:

$$N = \sqrt{\frac{5,000}{3}}$$

$$= \sqrt{1,667}$$

$$= 41.$$

The transformer should, therefore, have a primary-to-secondary turns ratio of 41:1. In practice, ready-wound transformers generally available for loudspeaker use have round-number ratios of 40:1, 50:1, 60:1 and so on, and it would be quite in order to employ a 40:1 component for the simple application just described. (This last point applies, mainly, to home-experimenter and small-scale production applications. A large-scale manufacturer of sound reproducing equipment—including radio and television sets—would have transformers wound to suit his designs, and these could well be given turns ratio figures which do not fall into the “round-number” category.)

The transformer in Fig. 309 is usually described as a *speaker transformer*, and it is a component specifically manufactured for the application. The anode current of the triode flows through the primary, varying in amplitude according to the alternating voltage applied to the triode grid. The current flowing in the primary can, in consequence, be described as a direct current on which is superimposed an alternating current. Only the alternating current appears in the secondary, for application to the loudspeaker. An important point is that the transformer primary has to be wound with wire which is sufficiently thick to pass the anode current without overheating or burning out, and a necessary specification for a speaker transformer is the maximum direct current which may flow in its primary. Because of the direct current in the primary, speaker transformers intended for operation in the circuit of Fig. 309 have their laminations butt-jointed rather than interleaved.³

³ When a direct current flows in the primary of a transformer, a butt-jointed construction (which would, for instance, be given by having all E laminations on one side and all I laminations on the other side) prevents the core from approaching saturation as closely as would occur with interleaved laminations (alternate E and I laminations on each side). See “Understanding Radio” in the June 1963 issue.

It should be mentioned that, in the earlier days of radio, it was a very common practice to employ triodes as power amplifier valves driving loudspeakers, these valves being designed to pass higher anode currents than triodes intended for operation as voltage amplifiers. Nowadays, however, it is the custom to use more complex valves for power amplifier applications, as these enable higher efficiencies to be achieved. A speaker transformer is still employed to couple the valve to the loudspeaker, and the procedure for finding the ratio it should have remains unaltered.

A final point is that a valve driving a loudspeaker in a circuit such as that of Fig. 309 may also be described as the *output valve* (of the sound reproducing equipment in which it is fitted). The speaker transformer may, similarly, be called the *output transformer*.

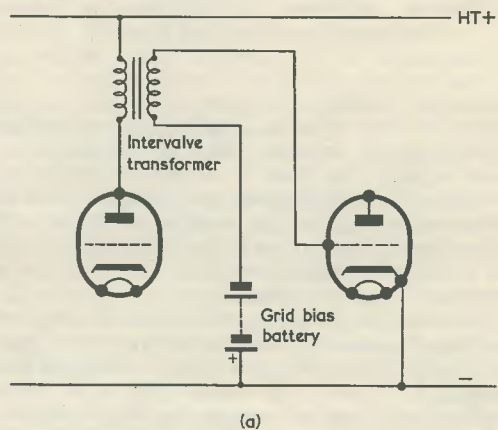

(a)

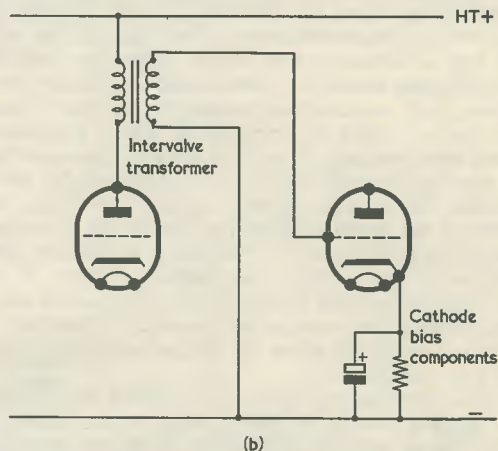

(b)

Fig. 310 (a). Coupling one a.f. amplifier valve to the next by way of an intervalve transformer. The grid and cathode circuits of the first triode and the anode circuit of the second triode are not shown, and may take up any of the forms already described (b). The triode following the intervalve transformer may have cathode bias, as illustrated here. The cathode bias capacitor is shown as an electrolytic component, as is normal for a.f. amplifier applications

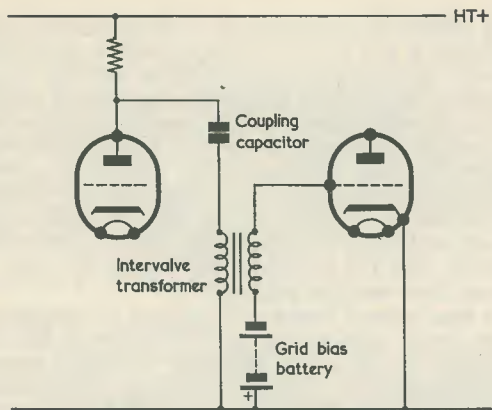

Fig. 311. An alternative method of connecting up an intervalve transformer. In this circuit no direct current flows through the primary

Intervalve Coupling

Since it is possible to employ a transformer to couple a power amplifier valve to a loudspeaker it would appear that such a component could, with advantage, be used between two valves in an audio frequency amplifier. The obvious advantage given by the transformer is that it could be a step-up type, and could therefore increase the overall amplification provided by the two valves.

Transformers were frequently used for intervalve coupling in sound reproducing equipment before the war and, since the principles involved are still applicable, we will now briefly review the circuits employed and their advantages and disadvantages.

Fig. 310 (a) shows a transformer coupling one a.f. amplifying valve to the next. The transformer could, in a practical circuit, have a ratio of the order of 1:6, whereupon the output from the amplifier will become six times greater than would have been given had resistance-capacitance coupling (which, of course, offers no increase in signal amplitude) been used instead. It will be noticed that grid bias is applied by way of the secondary of the transformer. As with the speaker transformer of Fig. 309, there is no flow of direct current in the secondary winding, and it may therefore be considered as a generator providing a stepped-up version of the alternating voltage at the anode of the first valve. An alternative, and equally suitable, method of biasing would be given by the cathode bias circuit of Fig. 301 (b).

The main advantage of the coupling transformer, as already stated, is that it provides an increase in the overall amplification offered by the amplifier. A second advantage is that the primary of the transformer has a low resistance, with the result that the anode of the first valve has a higher high tension voltage than would be given with resistance-capacitance coupling. This advantage can be useful if the available high tension supply voltage is low compared with the requirements of the first valve. On the debit side is the fact that the transformer has to

deal with alternating voltages ranging over the whole a.f. band of frequencies, which means that it requires a high permeability in its core to prevent attenuation (i.e. diminution) of the lower audio frequencies, and low self-capacitances in its windings to prevent attenuation of the higher audio frequencies.⁴ There are other, more complicated, factors which can also cause a degradation in the audio frequency signal applied to the transformer primary, and these all add to the fact that, if the audio frequency signal is not to be seriously distorted from its original form, the transformer has to be a carefully designed and relatively expensive component. It follows that, if a cheap component is used then quite significant distortion may result.

A further disadvantage of the transformer when used for intervalve coupling in an a.f. amplifier is that, unless it is efficiently shielded, a magnetic field appears about it, and this may interact with other inductive components. Or, again, currents may be induced in the transformer by the field from another inductive component.

When, as occurred in the earlier days, valves were relatively expensive and bulky, the extra audio frequency voltage amplification offered by an intervalve transformer was frequently beneficial. Since the audio quality given by loudspeakers at that time was not very high, it became possible to employ a relatively cheap transformer and accept the further distortion it introduced. So far as valve equipment is concerned the situation is nowadays completely different because miniature valves offering high degrees of amplification are available at low cost, and there is little point in employing a relatively bulky and costly intervalve coupling transformer which may introduce distortion instead of the simple resistor and capacitor required by resistance-capacitance coupling.

A variation on the circuit of Fig. 310 (a) is shown in Fig. 311. In this instance, no direct current flows through the primary of the transformer, with the result that it can be made up in miniature form with a core of small, high permeability, laminations. These may be interleaved, as there is now no direct anode current in the primary. The alternating audio frequency voltage at the anode appears across the primary by way of the coupling capacitor, which will have a value which presents a low reactance over the audio frequencies. The only advantage offered by the circuit of Fig. 311, when compared with normal resistance-capacitance coupling, is that the transformer offers a step-up in signal voltage. The remaining disadvantages of transformer intervalve coupling still apply.

Phase Reversal

An important feature of valve amplification is that the alternating voltage appearing at the anode is 180° out of phase with that applied to the grid.

⁴ Too low a permeability in the core could result in too low an inductive reactance in the transformer primary at the lower audio frequencies. In the high frequency case, the reactances offered by the self-capacitances could become sufficiently low at the higher audio frequencies to be comparable with the inductive reactances of the transformer.

This point may be readily perceived if we examine Fig. 312, in which the alternating voltage waveform at the grid is shown directly below that at the anode. At point A of the grid waveform, the alternating voltage is zero, and the grid is at the same potential as that provided by the grid bias battery. After point A the grid voltage goes positive, with the result that anode current increases. An increase in anode current causes an increase in the voltage dropped across the anode load resistor. The high tension supply voltage is fixed, and this increase in voltage across the resistor can only result in the anode going *negative* of the potential it previously held. The process continues as grid voltage goes more positive, with the anode voltage going correspondingly more negative. The grid voltage reaches its positive peak at point B, and the anode voltage arrives at its negative peak at the same instant. After point B the grid starts to go negative. Anode current, in consequence, starts to reduce as, also, does the voltage dropped across the anode load resistor. The result is that the anode now starts to go *positive*, reaching its positive peak when the grid voltage is at its most negative peak, at point C. Finally, the grid voltage goes positive again, from point C to point D, and the anode voltage goes correspondingly negative as a result. As is evident from Fig. 312, the result is an alternating waveform at the anode which is 180° out of phase with that at the grid.

The Cathode Follower

It is possible to employ a valve in different circuits to the basic type we have considered up to now, wherein the input signal was applied to the grid and the output signal was obtained from the anode. It will be helpful to briefly consider these alternative modes of operation, mainly in terms of the phase relationship between input and output alternating voltages.

When, last month, we considered the cathode bias circuit, we saw that, by inserting a resistor in the cathode circuit as in Fig. 313 (a), a bias voltage was applied to the cathode. We had, however, to connect a large value capacitor across the cathode resistor to enable a useful bias circuit to be obtained because, without such a capacitor, the cathode tended to go positive when the grid went positive and *vice versa*, therefore effectively reducing the signal voltage appearing between the grid and cathode.

It is possible to make good use of this effect by purposely omitting the high value capacitor, by increasing the value of the cathode resistor and by connecting the anode direct to the h.t. positive terminal. (See Fig. 313 (b).) An alternating voltage with suitable bias is then applied to the grid, and an output is taken from the cathode. Just as occurred with the cathode bias circuit before the high value capacitor was added, the cathode will go positive when the grid goes positive and negative when the grid goes negative. In other words an alternating voltage will appear at the cathode and

this will be in phase with the alternating voltage at the grid. An output for a further stage may then be obtained via a capacitor, as shown.

The amplitude of the alternating voltage at the cathode in Fig. 313 (b) will be greater than occurred in the previous cathode bias instance, because we have increased the value of the cathode resistor. Nevertheless, however much we increase the value of this resistor, the alternating voltage at the cathode will always be less than the alternating voltage at the grid and can never become equal to it. With a practical circuit, the amplitude at the cathode will be of the order of 0.9 times the amplitude at the grid. Despite the fact that a circuit of this type offers no voltage amplification it is still very useful for some applications.

A source of grid bias voltage was employed in Fig. 313 (b), but an alternative method of obtaining bias is shown in Fig. 313 (c). In this case we fit a standard cathode bias resistor and capacitor, the grid resistor being connected to the lower end of these two components. Very similar results (together with a saving of a component) will be given by deleting the capacitor, as in Fig. 313 (d).⁵ The signal input to the grid may be obtained via a capacitor.

A valve employed in the circuits of Figs. 313 (b), (c) and (d) is described as a *cathode follower*. The name is derived from the fact that the voltage on the cathode "follows" that on the grid.

An interesting adaptation of the normal valve amplifier and the cathode follower circuit is shown in Fig. 314. In this diagram the alternating voltage at the cathode is in phase with the input alternating voltage at the grid, whilst the alternating voltage at

⁵ The removal of the capacitor may even be beneficial as its inclusion in the circuit results in the cathode having different a.c. and d.c. loads, these being particularly at variance if the lower cathode resistor is not high in value compared with the upper cathode bias resistor.

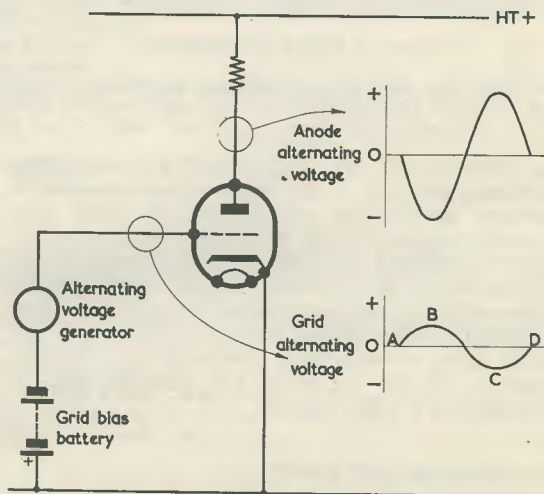

Fig. 312. Illustrating the fact that the alternating voltage at the anode is 180° out of phase with that at the grid

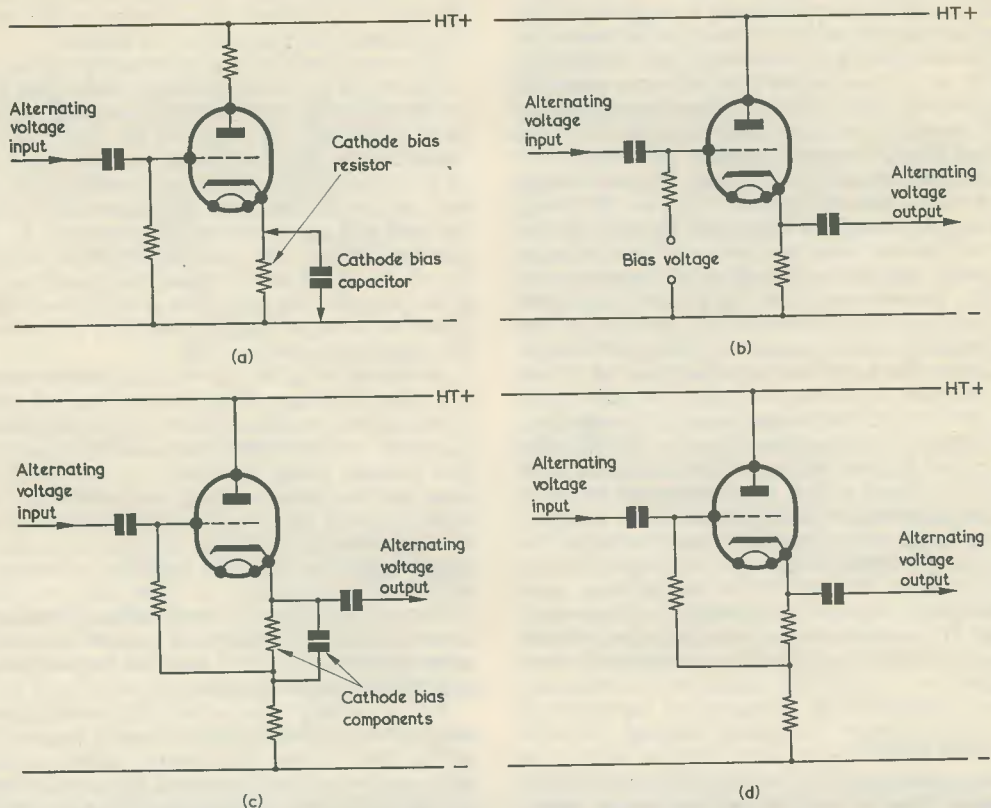

Fig. 313 (a). A cathode bias voltage may be obtained by inserting a resistor in series with the cathode. It is necessary, however, to add a high value capacitor across the resistor to prevent the input alternating voltage appearing at the cathode

(b). The cathode follower circuit. This takes advantage of the fact that the cathode voltage "follows" the grid voltage, whereupon an alternating voltage output becomes available at the cathode. Since the cathode resistor is now much higher in value than in (a), the cathode carries a much higher positive potential, and a suitable bias voltage is applied to the lower end of the grid resistor

(c). An alternative method of obtaining bias. The grid resistor is returned to the lower end of a standard cathode bias resistor and capacitor

(d). It is possible to obtain very similar results with the cathode bias capacitor of (c) omitted

the anode is 180° out of phase with the alternating voltage at the grid. If the resistors in the anode and cathode circuits are made equal in value (the cathode resistor consists of R_2 plus R_1) the out of phase alternating voltages at anode and cathode become equal in amplitude. Equal voltage amplitudes are bound to appear under these circumstances because the same current (the anode current of the valve) flows through both the anode and cathode resistors. In the circuit of Fig. 314 the valve is described as a *phase splitter*.

The Grounded Grid Circuit

Occasionally, a valve may be connected in the manner shown in Fig. 315. In this case the input signal is applied to the cathode instead of the grid. However, the alternating voltage still appears

between cathode and grid, and so an amplified version appears at the anode and may be taken off via a capacitor. Since the cathode going positive has the same effect on the valve's electron stream as the grid going negative, the phase relationship between input and output is opposite from that given in Fig. 312. When, in Fig. 315, the cathode goes positive so also does the anode, and the output alternating voltage is in phase with the input alternating voltage.

The circuit of Fig. 315 is sometimes described as an *earthed grid* amplifier, the term deriving from the fact that the grid is at "earth potential" (i.e., so far as input and output alternating voltages are concerned, the grid has a fixed reference potential which does not change). It is much more common, however, to describe the circuit as a *grounded grid* amplifier, the alliterative form deriving from the

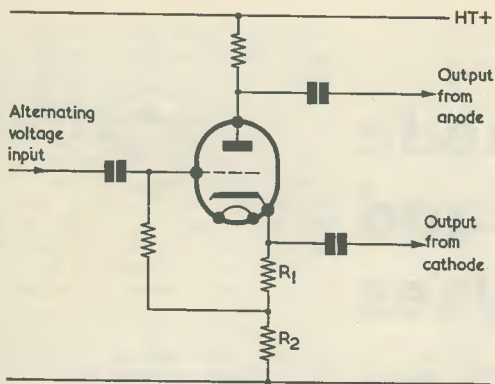

Fig. 314. Combining the normal amplifier circuit and the cathode follower to obtain a phase splitter circuit

American term "ground", which is synonymous here with "earth".

More Complex Valves

The circuits we have discussed this month have been demonstrated with triodes, but it should be pointed out that they can incorporate valves having more complex electrode structures than has the

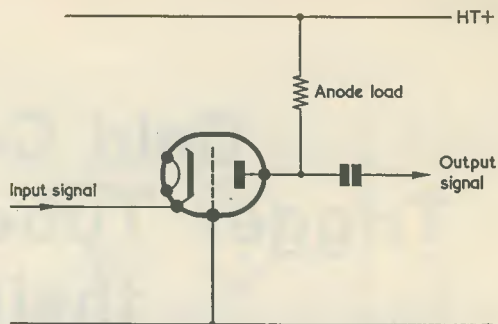

Fig. 315. The grounded grid amplifier. For simplicity, bias arrangements are not shown. In practice they would ensure that the grid is held negative of the cathode, as with the other amplifier circuits

triode. Operation with such valves still follows the same basic principles as those described.

Next Month

In next month's issue we shall continue to discuss basic attributes of the triode, and we shall show how it may be coupled to a diode detector circuit in order to amplify the detected audio frequencies the latter provides.

COURSES OF INSTRUCTION

Brentford Centre for Adult Education, Clifden Road, Brentford
Commencing 21st September, 1965

Radio and Television Servicing

Electron theory, magnetism, resistors, capacitors and inductors. Valves and transistors. Test equipment. Circuits. Fault finding. The course should enable the layman to keep his radio and television set in good repair, and prevent accidents from ignorant handling.

Tuesday (1st year). Thursday (2nd year).

Radio Amateurs' Course

This course is in preparation for the City and Guilds Examination which qualifies the successful candidate for recognition by the Postmaster-General for the purpose of Radio Transmission. The work includes: simple magnetism and electricity, principles of radio, valves and transistors and circuits, radio receivers, low-power transmitters, aerials, measurement of frequency meters. After the examination the course will include lectures on equipment design.

Monday.

Mathematics of Radio

This course has been especially designed to help those who are interested in radio but need help to comprehend the mathematics involved. It will be useful both to those taking radio servicing and to those studying for the R.A.E. The course will start on 29th October, 1965, and end on 29th April, 1966. Fee is £1 or as an extra class 5s.

Friday (from 29th October, 1965).

Enrolment dates: 9th, 10th, 13th, 14th and 15th September, 1965, 7-7 p.m.

Technical College, Waterdale, Doncaster

C. & G. Radio Amateurs Examination

Series of lectures in preparation for this examination commences on 22nd September and every Wednesday evening from 7 to 9 p.m. Course fee is £2 6s. 6d., enrolment during day or evening 13th, 14th or 15th September at the College.

Western Road Evening School, Sheffield, 10

Course for the R.A.E. will be held commencing on Wednesday, 22nd September at 7 p.m. at the School, enrolment week commencing 13th September. Contact J. Bell, G3JON for further details.

Evening Education Centre, 28 Beckenham Road, Beckenham, Kent

Course in radio theory in preparation for the R.A.E. will be held at the Centre every Thursday commencing 30th September. During the Autumn term only, instruction in Morse will be given on Mondays, commencing 27th September. Further details may be obtained from M. D. Bass, B.Sc., G3OJE, 42 Clevedon Road, London, S.E.20, or at the Centre during enrolment, 20th-22nd September.

Bradford Technical College

Course in preparation for the R.A.E. Classes will be held on Wednesday evenings from 7 to 9 p.m. Registration takes place during week beginning 13th September, fee will be 30s. (over 18 on 1st September). There is no fee for students under 18 years of age.

Cold Cathode Trigger Tubes and their Uses

By J. B. DANCE, M.Sc.

TRIGGER TUBES ARE BASICALLY similar to cold cathode diodes,¹ but a third electrode known as a trigger or starter is employed in addition to the main anode and cathode. This trigger electrode can be used to cause the main anode-to-cathode gap to conduct, but cannot be used to reduce the flow of anode current. Thus the trigger electrode acts like the grid of a thyatron rather than the grid of a hard valve. Trigger tubes are filled with an inert gas, often neon, at a fairly low pressure.

A resistive load must always be used when cold cathode tubes are employed. The simple circuit of Fig. 1, in which the trigger electrode is earthed, will be used to explain the basic action of a cold cathode tube. As the h.t. potential, V_b , is gradually increased from a low value no appreciable current flows initially, and the anode voltage therefore equals the h.t. supply voltage. Quite suddenly, when the h.t. voltage reaches the striking voltage of the tube, V_s , the anode-to-cathode gap

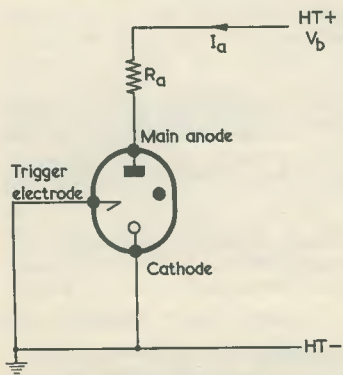

Fig. 1. Demonstrating the cold cathode trigger tube

conducts and the anode voltage falls to the maintaining voltage of the tube, V_m . This voltage is almost independent of the current passing through the tube. If the Ohm's Law equation is applied to the anode resistor, R_a , it can be seen that the current passing through the tube, I_a , will have the value

$$I_a = \frac{V_b - V_m}{R_a}$$

Thus the current passing through any particular tube is determined by the value of the load resistor, R_a , and the supply voltage, V_b . An excessive current will damage the tube. The anode-cathode voltage must be reduced below V_m to extinguish the tube (that is, to stop the conduction). A conducting tube glows with a reddish light; this is a great help in servicing equipment which employs cold cathode tubes.

Trigger tubes are often used with an h.t. supply voltage between V_m and V_s . The trigger electrode is normally employed as an additional anode. As the trigger voltage is increased, the trigger-to-cathode gap suddenly conducts and provides charged particles or ions which initiate conduction in the anode circuit. The trigger-cathode spacing is smaller than that between anode and cathode and therefore the trigger voltage required to initiate conduction is smaller than the striking voltage for the main anode-to-cathode gap. Some of the ions formed in the trigger-cathode discharge pass into the main anode-to-cathode gap and reduce the striking potential of this gap almost to the maintaining voltage.

Trigger Tube Cathodes

The cathodes used in trigger tubes can be divided into two main types. Oxide coated cathodes of low work



Fig. 2. Methods of priming by means of an auxiliary discharge: (a) with a priming anode, (b) with a priming cathode and (c) with two priming electrodes

function are employed in low voltage trigger tubes, but pure metal cathodes of sputtered molybdenum or nickel can be used if close tolerance tubes of high reliability are required. In both types of tube some stray ionising particles are required to initiate a discharge. If the only sources of ionising particles are stray radioactive atoms and cosmic rays, there will be a statistical delay in the striking of a tube after the necessary potentials have been applied. Some form of "priming" is required to prevent this delay. Tubes with oxide coated cathodes are normally primed by the electrons liberated when light falls on the cathode, but a small amount of a radioactive material (such as tritium or nickel-63) is included in certain types of tube designed for use in a dim light.

Visible light will not cause electrons to be emitted from a cathode

of high work function and the ultra-violet light which could do so cannot pass through the glass of the tube. It is usual to employ one or two additional electrodes in this type of tube. A priming current flows to this electrode system whenever the tube is in use and provides a limited number of ions which can initiate the discharge. If too many ions are provided, the striking voltage of the tube will be lowered. The methods of priming by means of an auxiliary discharge are shown in Fig. 2. A fourth method is employed in the S.T.C. G1/371K high speed tube, in which light from an auxiliary discharge passes through a mica window and primes the main section of the tube by photo-emission.¹

Advantages

Trigger tubes are "on-off" devices. That is, they are either passing a current of the value given in the equation above or they are non-conducting. There are no intermediate states of partial conduction, as in a hard valve. Thus trigger tubes cannot be used to amplify waveforms (although they can be used to amplify pulses). The ions in the gas take time to be formed and to disappear, and trigger tubes cannot therefore be used at very high frequencies. Some trigger tubes cannot be used at frequencies above about 1 kc/s, whereas others can be used at up to about 100 kc/s.²

Trigger tubes, like most cold cathode tubes, are extremely reliable components when properly used, values of the order of 0.05% failures per thousand hours being obtained.³ Power gains of the order of ten thousand million times and current gains of the order of ten million times can easily be obtained with ordinary trigger tubes in very simple circuits. Special "electrometer" trigger tubes draw currents of less than a millionth of a microamp before conduction occurs, and provide power gains as great as one

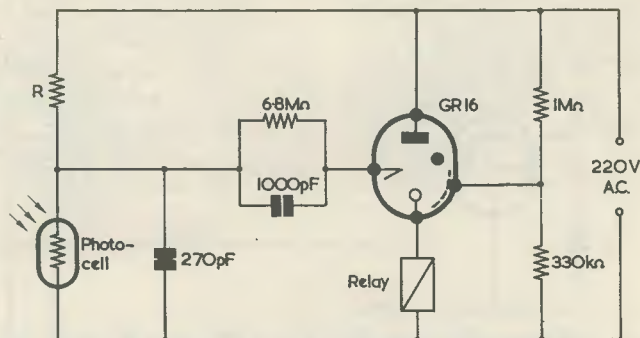

Fig. 4. A photosensitive circuit. The photo-cell is a photoconductive cell such as the ORP60 or ORP61. R is about 0.5 to 2.7M Ω , depending on the photoconductive cell used

million million times.⁴ Such devices are extremely useful in industrial equipment. No heaters are required and no power is consumed in the anode circuit when the tube is not conducting. There is no warming up period. Trigger tubes are very cheap. Many common types are about 8s. each, whilst one subminiature type can be obtained for 1s. 6d.

Applications

A few of the simpler applications of trigger tubes will now be discussed. Most of the circuits employ an alternating power supply so that the trigger tube is automatically extinguished during each alternate half cycle of the mains supply voltage.

Relay Operation

If a pair of small contacts (such as those of a thermostat) are used to control a large current, they will quickly be damaged. Such damage can be avoided by the use of a circuit such as that shown in Fig. 3 in which the Cerberus GR16 tube is employed.⁵ The tube will conduct during the positive half cycles of the supply voltage if and only if the contacts S are closed. The relay contacts may be designed to carry quite a large current.

If R₁ and the contacts S are interchanged with R₂, the relay will close when the contacts are opened.

Photosensitive Circuit

When the light intensity falling on the photoconductive cell C in Fig. 4 exceeds a certain value, the relay opens.⁶ It closes again when the light intensity falls below a certain smaller value. The difference in the values at which the relay opens and closes prevents the relay from

"chattering". The potential divider connected to the screening in the tube prevents spurious conduction. If the photoconductive cell and R are interchanged, the relay will open at low intensities of illumination and will close as the light intensity increases.

Timing Circuits

Trigger tubes are very commonly used in circuits which can provide time delays of up to about one hour. The basic circuit of such a timer is shown in Fig. 5. When S is closed the capacitor C charges through the high resistance R. After a time determined by the product of the values of R and C the trigger voltage will be great enough to cause the tube to conduct. The relay then closes. The time delay, t, is given by the equation

$$t = RC \log_e \frac{V_{bt}}{V_{bt} - V_{it}}$$

where V_{bt} is the trigger electrode supply voltage and V_{it} is the voltage at the trigger electrode when ignition occurs.

A general purpose trigger tube timing circuit is shown in Fig. 6.⁷ As shown in the Table, a wide range of delay times can be obtained by appropriate choice of the capacitor between the trigger electrode and cathode and of the resistor corresponding to R in Fig. 5. The relay should close at a current of less than 13mA. The total resistance of the relay and its series resistor should be 4k Ω . The Ericsson GTE130T trigger tube employs a priming anode (shown on the right hand side of the circuit symbol). The capacitor selected by S₂ commences to charge when the relay contacts A2 open as the reset switch S₃ is momentarily opened. The tube ignites after the

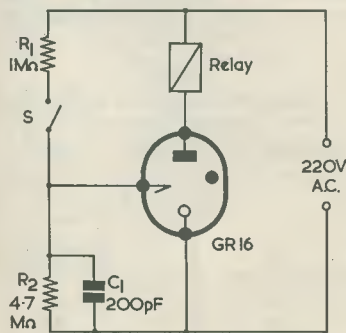

Fig. 3. A relay control circuit

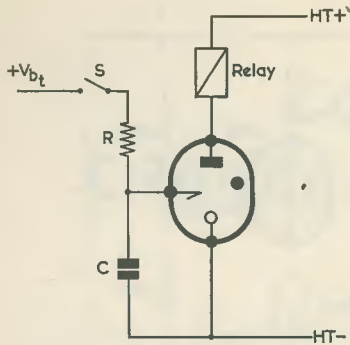

Fig. 5. The basic trigger tube timing circuit

preset interval and the relay contacts A1 close. The tube anode voltage is thereby lowered and the tube is extinguished, but the relay is held closed because a current passes through the contacts A1 instead of through the tube. When the relay closes, the contacts A2 short-circuit the capacitor selected by S₂.* When S₃ is opened momentarily, the current in the relay falls to zero so that A1 and A2 open. The capacitor selected by S₁ then commences to charge again and the tube fires at the preset interval after the operation of S₃. Other contacts on the relay are used as output contacts to operate

* It may be advisable to insert a low-value limiting resistor (say 10Ω) in series with contacts A2 to prevent an excessive flow of current at the instant of closing.
—EDITOR

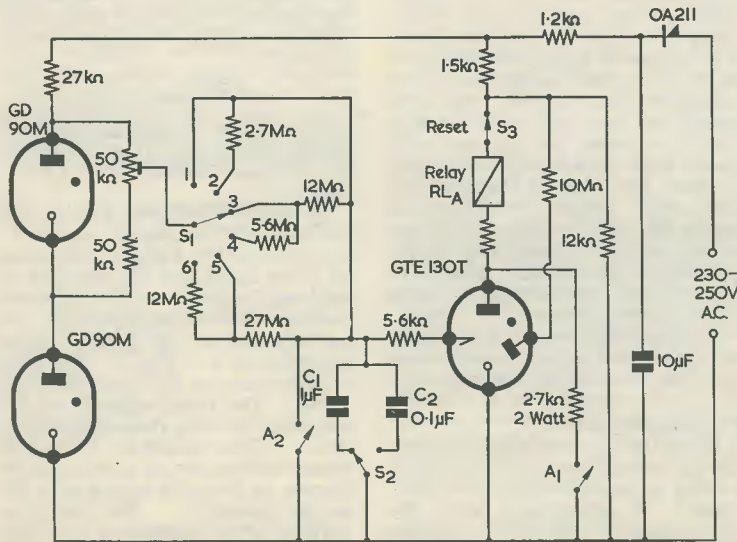

Fig. 6. A general purpose timer. The timing capacitor, C₁, must not be an electrolytic component

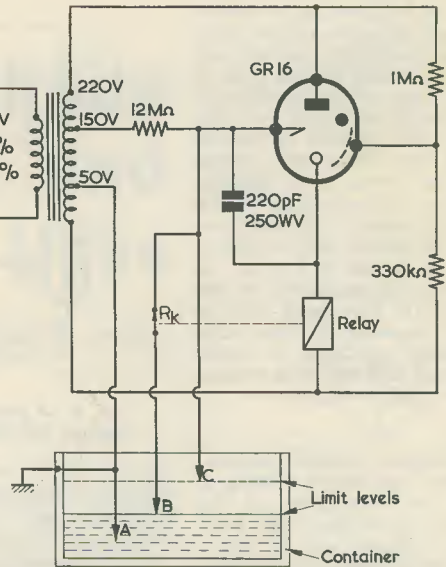

Fig. 7. Using a trigger tube to control liquid level

any equipment after the preset time interval.

Such a circuit has obvious uses in photographic enlarging, etc. Similar circuits have been published by other trigger tube manufacturers^{8,9}.

Level Control

Trigger tube circuits are very useful for controlling the level of a liquid in a vessel. The liquid must possess some very slight conductivity.

A typical circuit is shown in Fig. 7¹⁰. When the liquid in the vessel falls below the point B, the relay closes and operates a pump which raises the liquid level. The relay contacts, R_k, open so that the pump is not switched off until the level reaches C. The difference in the levels B and C prevents the relay from operating frequently or "chattering". The resistance between the two electrodes immersed in the liquid should not exceed about 100kΩ in this circuit.

If the 50 and 150 volt connections to the transformer are interchanged, the relay will open when the liquid falls below point B and close when it rises above point C.

Other Uses

Trigger tubes are much used in counting, as multivibrators (which may be astable, monostable or bistable), in telephone¹¹ and other routing circuits, in welding timers, in

TABLE

Timing periods offered in Fig. 6

Position of S ₁	Time (secs.)	
	0.1μF	1μF
1	1.0	10
2	1.5	15
3	2.1	21
4	3.1	31
5	4.8	48
6	7.0	70

electronic fence controls¹¹, in various types of protective circuits, etc.

In most cases valve or transistor circuits can be designed for the same function, but trigger tubes may be preferred for reasons of cost or reliability.

Cerberus tubes may be obtained from Walmore Electronics Ltd., 11-15 Betterton Street, Drury Lane, London, W.C.2.

References

1. J. B. Dance. "Cold Cathode Diodes and Their Uses." *The Radio Constructor*, Vol. 17, No. 6, p. 392 (January 1964).
2. "G1/371K High Speed Trigger Tube" S.T.C. Application Report MS/118.
3. M. E. Bond. "The Trigger Tube—Reliability and Ratings", I.E.R.E. Symposium, March 1964.
4. D. M. Neale. "A Survey of Cold Cathode Discharge Tubes", *The Radio and Electronic Engineer*, Vol. 27, No. 2 (February 1964).
5. Cerberus Applications Manual, 1964.
6. "Photoelectric Relay with Photo-

resistor and GR16" Cerberus Sheet No. 52.15.

7. "Cold Cathode Trigger Tubes". Published by Ericsson Telephones, May 1963.

8. G. O. Crowther and M. J. Potter. "Timing Circuits using the Cold Cathode Stable Trigger Tube type Z803U", *Mullard Technical Communications*, Vol. 2, No. 15, p. 113 (September 1955).

9. "Zeitkreise Mit GR16". Cerberus Sheet 2.12.16D.

10. "Level Control with GR16". Cerberus sheet 51.13.

11. "Philips Cold Cathode Trigger Tubes" Philips Publication 20/092/D/E-1-62.

Power Amplifier for Portable Radio

By J. R. BROOKS

Add a 3-watt output stage powered by the car battery to a transistor portable and you obtain a high level output whilst you drive, together with low running costs. The add-on amplifier may conveniently be fitted in a cabinet built to accept the portable receiver, but this is not essential. The car should have a 12-volt battery, and a positive earth is assumed

DISTORTION, LOW VOLUME AND POOR SENSITIVITY due to run-down batteries often mar the pleasure given by portable transistor sets used in cars. Motorists who make long runs and like to enjoy continuous listening with good volume

Components List (Fig. 1)

Resistors

- R₁ 250Ω 2 watt pre-set
- R₂ 15Ω 1 watt
- R₃ 1Ω 1 watt

Capacitors

(All capacitors are electrolytic)

- C₁ 1,000μF 25V wkg.
- C₂ 500μF 25V wkg.

Transformers

- T₁ Repanco type TT11
- T₂ Repanco type TT12

Transistor

- TR₁ OC26 or equivalent

Switch

- S₁ s.p.s.t. toggle

Pilot Lamp

- PL₁ 12-volt pilot lamp and holder

Loudspeaker

- 3Ω impedance, size to suit (e.g. 7 x 4in)

and good reception will find the unit described here of special interest. It employs an additional output stage to drive a loudspeaker, the necessary power being obtained from the car battery.

A reliable and high output is maintained with the car battery, thus overcoming the inconvenience of frequent replacement of the dry battery. For ease of handling, the add-on amplifier, with its own speaker, is contained in a compact cabinet with temporary housing for the receiver itself. As is shown in the accompanying illustrations, the portable receiver then fits into this cabinet.

Design

The amplifier has been designed for use with the majority of transistor receivers, both manufactured and home built. The drive for the power transistor is taken from the jack socket generally provided for a personal ear-phone. The modifications required if such a socket is not available are discussed below.

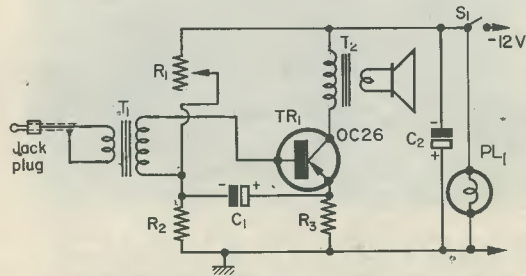

Fig. 1. The circuit of the add-on amplifier

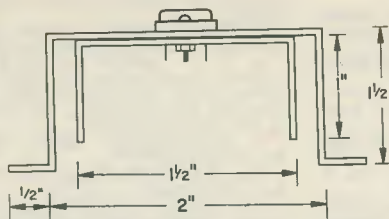

Fig. 2. End view of the heat sink. The length is $4\frac{1}{2}$ in, and the transistor mounting bolts hold the two sections together

The circuit, shown in Fig. 1, is based on an OC26 power transistor. This component has the required characteristics but any transistor with similar ratings may be used.

The resistors are high wattage types. The un-bypassed resistor R_3 should be wirewound. Its purpose is to reduce distortion by providing degeneration in the emitter circuit.

Resistor R_1 is a pre-set component. On setting up the circuit an ammeter should be connected in series with the collector lead of the transistor and resistor R_1 adjusted (starting with full resistance inserted in circuit) to give a no-signal collector current of 400mA (0.4A). This ensures that the transistor used is correctly biased. The resistance found in R_1 may now be measured and a fixed resistor substituted. Alternatively, the pre-set component may be left in circuit. A typical value for R_1 is around 100 Ω .

Transformers T_1 and T_2 are standard driver and output transformers for the OC26. Repanco components were used in the prototype and were found most satisfactory. In both cases the winding wire is brought out to the tag connections and the thinner wire represents the primary.

Construction

Construction is simple. Using the tags on the transformers, the resistors and capacitors are

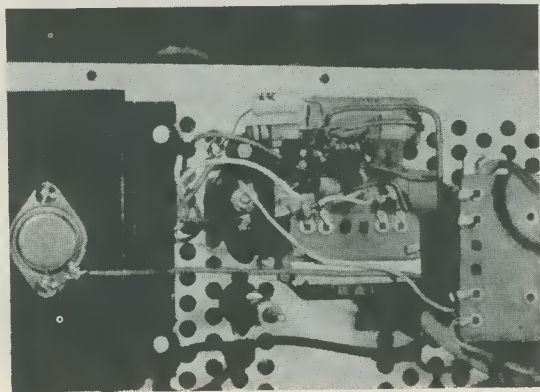

Detail of the amplifier chassis. The OC26 is to the left, mounted on its heat sink, and the input transformer is in the centre. Between the input transformer and the heat sink are (above) a panel light holder and (below) the aerial input plug for the receiver

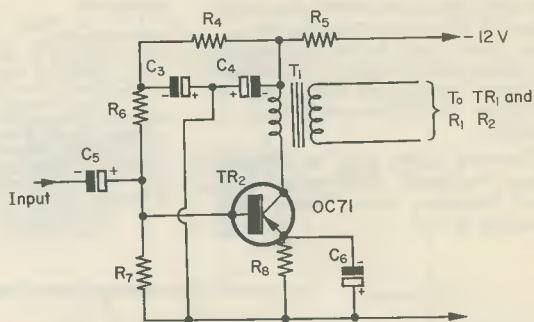

Fig. 3. Additional gain may be given, where required, by adding an a.f. stage before the OC26. Transformer T_1 is the same component as is shown in Fig. 1

Components List (Fig. 3)

Resistors

R_4	560 Ω	$\frac{1}{2}$ watt
R_5	560 Ω	$\frac{1}{2}$ watt
R_6	15k Ω	$\frac{1}{4}$ watt
R_7	10k Ω	$\frac{1}{4}$ watt
R_8	470 Ω	$\frac{1}{2}$ watt

Capacitors

(All capacitors are electrolytic)

C_3	100 μ F	25V wkg.
C_4	100 μ F	25V wkg.
C_5	6 μ F	6V wkg.
C_6	100 μ F	6V wkg.

Transistor

TR₂ OC71 or equivalent

robust enough to be self-supporting. It is possibly better practice, however, to incorporate a small tagstrip, especially since the unit is designed for portable use. All the components, with the exception of the on-off switch and loudspeaker, were mounted on a sheet of metal used as the back of the writer's cabinet. This forms a chassis and is

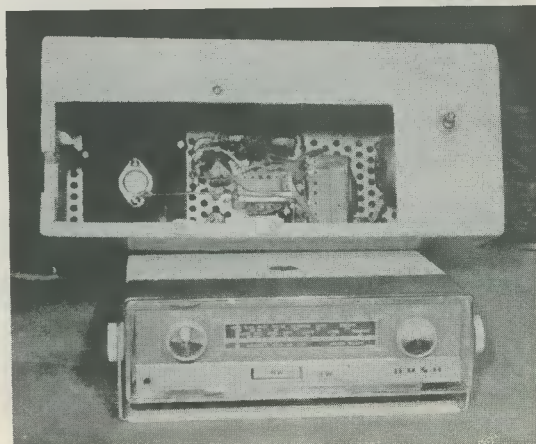

The receiver removed from the amplifier cabinet

at positive supply line potential. Further details are shown in the photographs. Following usual practice, the base and emitter leads of the transistor should be gripped with a pair of pliers when the wires are soldered to them.

The heat sink for the OC26 is illustrated in Fig. 2. The material is 16 or 18 s.w.g. aluminium and the transistor was mounted directly on to the metal. The heat sink was then fixed to the chassis by four OBA nylon nuts and bolts, being spaced from it by washers of the same material. This insulates the sink from the chassis or positive line. The more usual method is to electrically insulate the transistor from the sink with mica washers but this reduces the thermal conductivity between the two, and if this latter method is employed the size of the sink may need to be increased. It is advantageous to mount the heat sink vertically and, after fixing the transistor, to paint the whole matt black.

Coupling To The Receiver

The primary of the driver transformer, T_1 , is connected to a short length of screened lead, terminating in a small jack-plug which fits the ear-piece socket on the receiver. In the majority of portables it will be found that the output for the earphone is taken from the driver for the push-pull output stage or from the output circuit itself. There is sufficient power at these points to give a satisfactory output on the external amplifier. If this is not the case, or if an output socket is not provided, the additional circuitry shown in Fig. 3 should be used and the output taken from the volume control of the receiver; at the same time, the output stage in the set should be rendered in-operative by disconnecting the supply voltage to this circuit.

It will be noted that there is no direct connection between the chassis of the add-on amplifier and the transistor receiver, although an indirect connection may be given if the portable is used with a properly fitted car aerial, this occurring via the aerial lead screening, the car frame and the positive supply lead to the amplifier. Such a connection was found satisfactory with the author's unit. If a properly fitted car aerial is not employed the radio will probably not be earthed, in which case the provision of a direct connection between the radio and amplifier chassis may serve to reduce interference in some cases. No connection to the receiver chassis is made by way of the input lead. If there were, and if, as may be the case, neither terminal of the headphone socket were earthed, insertion of the pick-up plug could short-circuit the signal voltage. For this reason both input leads are floating, although this may be an unnecessary precaution.

Cabinet

The design and measurements of the cabinet for the amplifier and speaker with temporary housing for the receiver are dependent on the size of the receiver and the position of its controls.

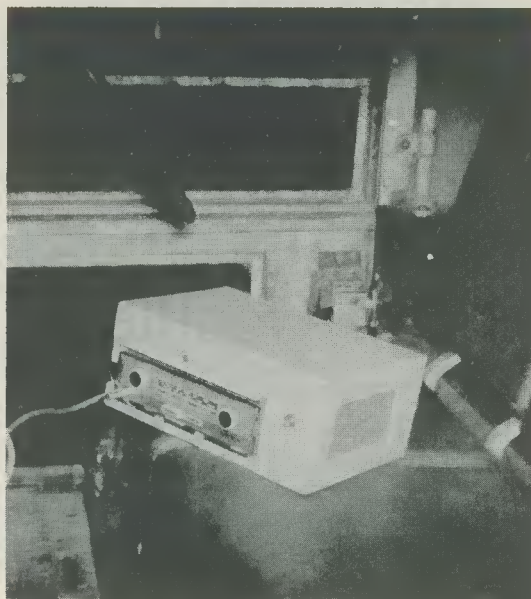

The complete unit, with the portable receiver fitted in the cabinet of the add-on amplifier

But in any case the construction can be quite a simple job and can be safely left to the individual ideas of the reader. In the prototype the top, bottom and side were 9mm plywood, to which a hardboard front was assembled with pinned butt joints. The metal back-piece provided rigidity. The receiver is held in place by fillets inside the cabinet and by metal lugs on the front edge.

The form of the receiver employed is well suited for incorporation in the amplifier cabinet, as may be seen from the illustration, and it should be easy to design a cabinet to contain most receivers. Since a flexible lead is used for the drive pick-up, the amplifier could also be built as a separate unit.

Results Obtained

The unit as constructed is trouble-free. It is used in a particularly noisy vehicle and with a normal car aerial, nevertheless the gain control on the receiver has to be backed off for comfortable listening. Of course the add-on amplifier will not prevent interference or fading, but it will provide more than adequate volume. Current drain is too small to register on the car ammeter and so need not give rise to any concern. Power from the car battery is obtained by way of two dash-mounted sockets, positive earth electrics used on the car corresponding to the positive earth transistor circuit. A non-reversible plug and socket is better than two separate sockets but *be sure that reversed polarity cannot occur while actually inserting the plug*. This could occur if the chassis were earthed to the car—e.g. via the screened aerial lead. A 12 volt, 2.2 watt indicator bulb together with holder completes the unit.

Transistor Beat Frequency Audio Oscillator

By D. BOLLEN

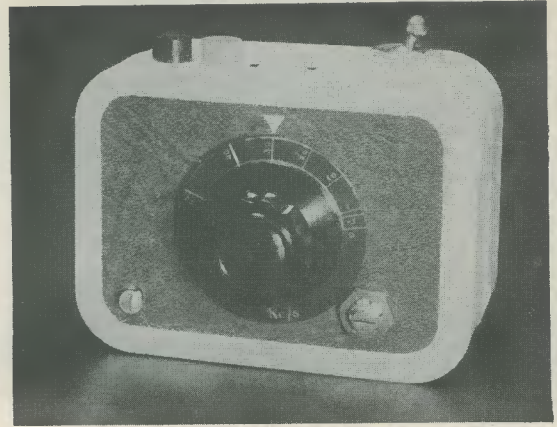

IT IS INTERESTING HOW CURRENT DEVELOPMENTS enable one to look again at circuits which were once popular but have now fallen out of favour. The Beat Frequency Oscillator is a case in point. Although widely used in the early days of radio for the generation of a.f. tones, it had an irritating defect. Heat from valves, and the consequent variations in component values, caused it to drift in use, and constant checking and resetting was necessary to maintain calibration. These early units also employed large components spread around on

—by modern standards—a massive chassis. Since low power transistors generate little heat and modern miniature components can be assembled efficiently in a small space with great mechanical rigidity, and therefore seem to favour the b.f.o. application, the unit described in this article was constructed to investigate the possibilities. It has proved to be remarkably satisfactory.

The prototype fits into a metal case (derived from two tobacco tins) measuring 2 x 3 x 4in with space to spare. The drift is not more than ± 5 c/s at any setting once the unit has settled down after a few minutes' operation, and the output frequency remains stable over long periods if the unit is not subjected to sudden heat changes. Small day-to-day variations caused by ambient temperature can be corrected by a set-zero control. The output level

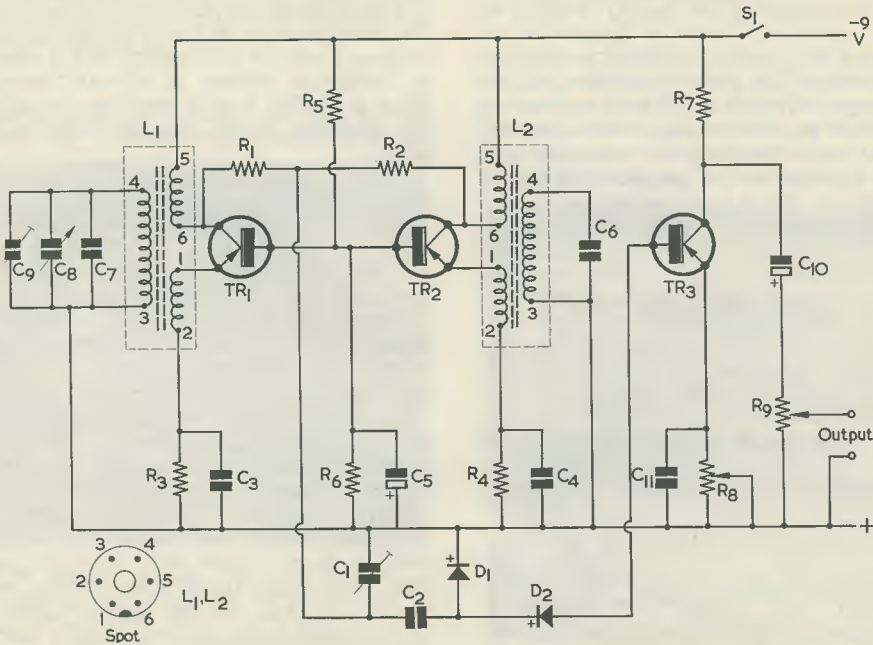

Fig. 1. The circuit of the transistorised beat frequency oscillator

is constant to within 2% from 25 c/s to 60 kc/s and is 3dB down at 10 c/s. With careful adjustment the instrument will go as low as 2 c/s. The great virtue of the b.f.o. circuit is that 10 c/s to 60 kc/s can be covered in one range only, and without switching. Modern Wien bridge oscillators require three or more switched positions to cover a frequency range of this type and the use of switches and ganged potentiometers makes a compact form of construction difficult.

Circuit Operation

Everyone is familiar with the whistles heard on a.m. radio receivers when adjacent signals beat against each other. The frequency of the whistle depends on how far apart the signals are. Thus, a station transmitting on 1,000 kc/s and another at 1,010 kc/s will produce a 10 kc/s beat note which can be heard in the receiver loudspeaker. This

Components List

Resistors

(All fixed values 10% $\frac{1}{4}$ watt)

- R_{1,2} 4.7k Ω
- R_{3,4} 3.3k Ω
- R₅ 10k Ω
- R₆ 4.7k Ω
- R₇ 3.3k Ω
- R₈ 2k Ω potentiometer, linear, pre-set
- R₉ 5k Ω potentiometer, log, edge-control

Capacitors

- C₁ 400pF, "postage stamp" trimmer
- C₂ 200pF, silver-mica or ceramic
- C_{3,4} 0.01 μ F, paper
- C₅ 1 μ F, electrolytic, 9V wkg.
- C_{6,7} 200pF, 2%, silver-mica
- C₈ 50pF air-spaced variable. (Jackson Bros. Type C804 would be suitable)
- C₉ 5pF ceramic tubular trimmer (adjustable earthed centre screw)
- C₁₀ 50 μ F, electrolytic, 15V wkg.
- C₁₁ 0.005 μ F, paper

Inductors

- L_{1,2} Medium wave oscillator coils type P50/1AC. (Weymouth)

Semiconductors

- D_{1,2} OA81
- TR_{1,2,3} OC44

Switch

- S₁ s.p.s.t., toggle

Battery

- 9-volt, type PP3

Miscellaneous

- 2 Output terminals
- Paxolin board
- Celluloid board
- Metal case (see text)

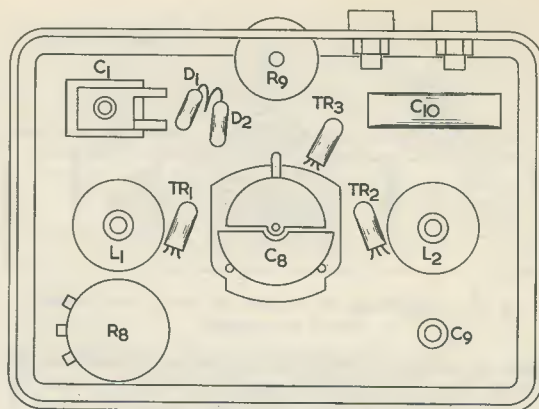
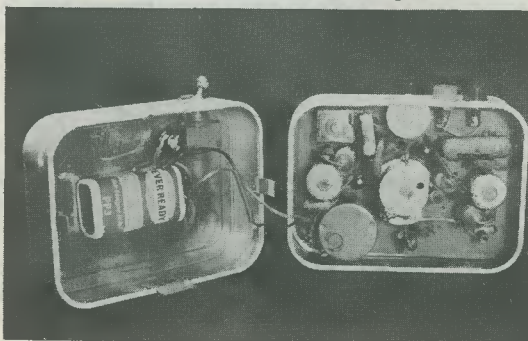

Fig. 2. Layout of principal components inside the case

annoying effect finds a useful application here. If one of two signals can be varied at will, a wide range of low frequencies become available. This is exactly what happens with the b.f.o.

From the circuit (Fig. 1) it will be seen that two oscillators, operating in the common base mode and sharing the same base bias network to minimise d.c. drift, feed the beat signal into a simple diode detector and amplifier. L₁ and L₂ are standard medium-wave transistor superhet oscillator coils tuned by fixed capacitors C₆ and C₇ to 700 kc/s.¹ In addition, L₁ has a 50pF variable capacitor, C₈, to provide the necessary variation between the two oscillators, and this is directly calibrated in terms of the resultant audio frequency. The 5pF trimmer, C₉, allows for slight variations which may occur in operation and final assembly, and serves also as a set-zero control. TR₃ not only amplifies but also provides correction for the inherent fall in output with this type of circuit above 20 kc/s, this being

¹ It may be mentioned in passing that, in normal receiver applications it is usual for tag 1 of the coils specified for L₁ and L₂ to connect to supply positive, tag 2 to emitter, tag 5 to collector and tag 6 to supply negative. The method of connection favoured by the author in Fig. 1 still enables regeneration to occur, as the connections to both the emitter and collector windings are transposed.—EDITOR.



In the prototype, the Paxolin board is fitted to the front half of the case, the battery and on-off switch being mounted on the other section. Springy metal clips are soldered to the sides of the rear section, enabling this to be clipped to the front section.

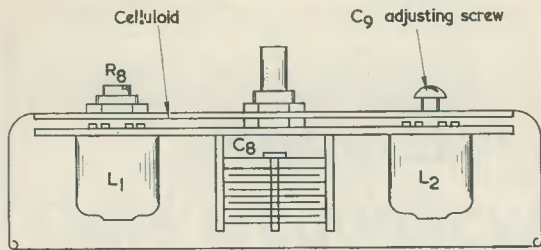

Fig. 3. Illustrating the manner in which the Paxolin board is mounted

done by means of selective negative feedback in its emitter circuit. The pre-set control R_8 , can be adjusted to give a high degree of linearity; and it must be remembered, of course, that any kind of negative feedback reduces output. When the unit is correctly set up, 350mV r.m.s. is available from the output terminals at the maximum setting of R_9 . This is adequate for most audio applications, but if a higher output is required at the expense of constant output voltage, R_8 , C_{11} , and C_1 can be dispensed with, to give approximately 1 volt r.m.s. Alternatively the range could be reduced to a maximum frequency of 20 kc/s by making C_8 20pF, thereby eliminating the need for correction. A better alternative is an additional stage of a.f. amplification, using another transistor.

TR_3 is biased by the negative voltage presented to its base by D_1 and D_2 , this arrangement being found to give the best result.² C_1 prevents pulling between the two oscillators at very low frequencies and improves the waveform. The high value of C_{10} ensures a good output at very low frequencies.

An intriguing application of this oscillator is in testing the selectivity of radio receivers. Because a small r.f. component is left unfiltered, the output can be picked up at either 700 kc/s or the harmonic at 1,400 kc/s without direct connection between the oscillator and the receiver. The degree of selectivity is immediately apparent if a sensitive a.c. voltmeter is connected across the speaker terminals of the receiver. The audio frequency at which a marked fall in output is indicated on the voltmeter will be directly shown on the dial of the b.f.o., and a response curve could be quickly plotted. It must be pointed out that the rectifiers used in some test meters can not always be relied upon to give good results above—and sometimes even below—10 kc/s, and a simple arrangement of a germanium diode and a 1 volt d.c. meter may be needed to give a more accurate comparative reading.

Construction

A piece of Paxolin approximately 4 x 3in was shaped to fit inside a tobacco tin of the dimensions indicated earlier, then drilled to take the two coils L_1 and L_2 , together with the associated components.

² To obtain a true "voltage-doubling" action in D_1 and D_2 , the second diode should really be followed by a capacitor, this being connected between the base of TR_3 and supply positive. However, as is stated in the text, the arrangement shown in Fig. 1 has been found to give best results in practice.—EDITOR.

(See Fig. 2.) The 50pF capacitor C_8 was mounted centrally, its threaded bush serving to secure the whole assembly to the face of the tin after wiring up. Holes were drilled in the front of the tin to take C_8 , the pre-set linearity control R_8 , and the 5pF tubular trimmer screw C_9 . A slot was also filed in the top of the tin to take the edge-control potentiometer R_9 , alongside the two output sockets.

The wiring was carried out on the underside of the Paxolin with 20 s.w.g. insulated wire, this being covered with a stout piece of celluloid cut to the same size as the Paxolin. The celluloid serves to insulate the wiring from the face of the tin and to clamp the assembly firmly, rather in the manner of a sandwich. (See Fig. 3.) A printed circuit could be used to advantage with this type of layout.

Alignment

It is better not to mount the unit inside its box until preliminary tests have been carried out. Connect the b.f.o. to a 9V battery and place it near a radio receiver tuned as near as possible to 700 kc/s (429 metres). Tests will be simplified if no existing stations come in on this frequency, so the aerial should be disconnected. If the receiver has a ferrite rod, it should be oriented to give minimum signal from the unwanted station. Set C_8 to minimum capacitance and the screw of C_9 to its central position, then adjust the dust core of L_2 until a hiss is heard in the receiver. Next trim the core of L_1 for a high pitched whistle, which should drop in frequency to a point where zero beat is reached. This is the correct setting. Further adjustment of the dust core, in or out, will cause the note to become audible again. Check that the cores of L_1 and L_2 are approximately in the same positions, in case one oscillator is working on a harmonic. If all is well, the b.f.o. can be assembled into its box. The screening effect of the metal will cut the amount of radiated r.f., but this will still be sufficient to continue the alignment. Some readjustment of L_1 may now be necessary, whereupon all subsequent adjustments are made by C_9 only. It is also worth checking, at this stage, that L_1 is tunable over its full range; this is done by resetting the receiver to approximately 55 kc/s below its original position, i.e. to 645 kc/s (465 metres). If C_8 is then adjusted to the other end of its travel, a hiss from the receiver should be apparent. Another test is to connect a pair of headphones to the output of the b.f.o. As C_8 is turned slowly away from its minimum position a rising note will be heard until it goes beyond audibility. Finally, pour a very small amount of hot candle wax carefully into the centre of each coil



Fig. 4. A simple output meter

to hold the dust core firmly in place.

The second stage of alignment is to ensure that the output of the generator is constant at all frequencies. Failing a valve voltmeter or oscilloscope, the only really satisfactory method is to make up the simple indicator shown in Fig. 4. Switching on the unit before the meter is connected prevents C_{10} charging through the sensitive movement. Set R_9 near maximum. With R_8 turned fully towards its lowest resistance, it will be found that the output falls gradually towards the maximum frequency setting of C_8 . Adjust R_8 in steps to reduce the output to a point where it does not vary over the whole range, excluding the very low frequencies. Now adjust C_1 and C_9 so that the b.f.o. output just oscillates (2 to 5 c/s) with C_8 near minimum. Repeat the adjustments to R_8 until the meter reading does not vary at all between 25 c/s and the highest frequencies, diminishes gradually below 25 c/s, and suddenly drops to nothing as zero beat is reached. Some meters may exhibit visible needle vibration at the lowest frequencies, but this should not be sufficient to cause damage.

Calibration

Without an oscilloscope and a frequency standard, precise calibration is difficult. A scale is given in Fig. 5 as a rough guide, and this should be fairly accurate so long as C_8 is a 50pF capacitor of similar type to the original, with semicircular vanes. It may be possible for those with good hearing to establish the 10.1 kc/s position by comparison with the whistle audible from most 405 line television

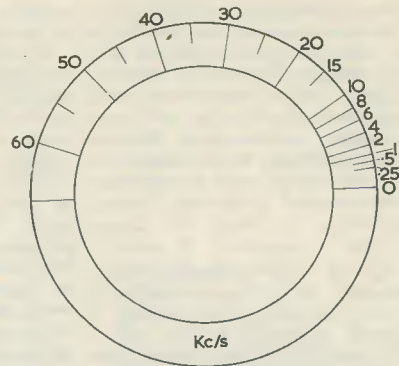

Fig. 5. The scale provided by the prototype

receivers (when synchronised), and 50 c/s can always be obtained from the mains frequency. A piano will give numerous calibration points below 3.515 kc/s. If a radio receiver is available with a large, finely marked tuning scale, the 10 kc/s points up to 50 kc/s may be located.

There are other ways of finding spot frequencies, for example, the tones radiated by the B.B.C. before and after normal transmissions.³ The owners of tape recorders or gramophones could, also, use the frequency test tapes and records that are readily available.

³ Immediately before the commencement of transmitter operation these are 1,000 c/s on Home Service and 440 c/s on Light Programme and Network Three. See *The Radio Constructor*, June 1962, page 819.—EDITOR.

RADIO TOPICS . . . by Recorder

THREE MONTHS AGO, IN THE June issue, I was enthusing over the advantages of transistors when compared with valves, and stated how, whenever I had to knock up an item of new equipment, I always checked first of all to see whether it would be possible to use transistors. If transistors could be used, the processes of construction and assembly were much simplified because there was then no need to provide a heater and h.t. supply or to carry out the metal-bashing involved in mounting valveholders.

I shall now proceed to talk, in complimentary terms, about valves! But this isn't a turncoat action on my part—it's merely the result of a number of queries from beginners

that have been directed my way. The queries have to do with those American-coded octal valves, of the 6K7 and 6SN7 variety, which are now available for a few shillings each and which represent, in consequence, a jolly good buy for those whose pockets aren't too deep. Quite a few of these valves may still be wartime production, whilst others will have been made since 1945.

Metal Valves

The first point that puzzles the beginner is that, whilst these valves are frequently referred to by a type code which consists of a figure, one or two letters and a figure, they often appear in mail order lists with the mystic letters "G"

or "GT" following. Thus, reference may be made in an article or in conversation to, say, a 6K7 but, when the newcomer to the hobby looks up the valves offered by suppliers, he may quite possibly find that no 6K7 appears at all. On the other hand there may be a 6K7G or a 6K7GT in the list, and the beginner immediately begins to wonder whether either of these is the same as a 6K7.

The short answer is that, apart from one important difference, the 6K7, the 6K7G and the 6K7GT are all *electrically* the same. The addition of the "G" or "GT" signifies a difference in construction.

The 6K7 and a fairly large range of similar valves with the same type of coding employ metal envelopes made of steel instead of glass envelopes. The lead-out wires of these metal valves are taken through glass beads forming vacuum-tight seals with the steel envelope. Such valves have a well-earned reputation amongst people who have used them as being exceptionally tough and rugged. Most of the older ex-Service types first

encountered them fitted in American radio and radar equipment during the war, and welcomed them as a pleasant change from the more fragile glass valves employed in British equipment. So far as I'm aware, metal valves with steel envelopes of the type we are discussing here have only been produced in the States, and there has been no production of them in this country.

The "G" or "GT" following the type number of a valve merely indicates that it has a glass, instead of a metal envelope. "G" and "GT" valves have been manufactured in Britain as well as in America. A "G" valve has a large bulbous glass envelope, whilst the "GT" version has a smaller glass envelope with parallel sides (and is sometimes referred to as a "bantam" type). To take an example of the relative dimensions of each type, the 6K7 r.f. pentode has a metal envelope slightly less than 1in in diameter, with a length of about 2½in from the top of the envelope to the bottom of the spigot; the 6K7G has a bulbous glass envelope with a maximum diameter of just over 1½in and a length of some 4in from the top of the envelope to the bottom of the spigot; whilst the 6K7GT has a straight-sided glass envelope with a diameter of about 1.1in and a length of around 3.2in from the top of the envelope to the bottom of the spigot. It so happens that the 6K7 has a top cap for connection to the signal grid. This top cap projects above the envelope in all three versions of the valve by a further 0.3in or so. Many of the valves in the "metal series" do not, incidentally, have top caps, all their connections being taken out to the pins at the bottom.

You may see, from the dimensions I've just quoted, that the smallest version of the valve is the metal type. The "GT" type is a little larger, whilst the "G" type is considerably larger.

We next come to the important difference I mentioned just now when stating that the valves are, otherwise, electrically the same. The difference is that the envelope of the metal version functions also as a screen, and it is connected internally to one of the pins (usually pin No. 1).

Replacements

The points I have just detailed are of some importance if it is intended to replace a valve in the series with another of like type

number but different construction in an item of equipment.

Space availability will almost always enable a metal valve to be replaced by its slightly larger "GT" equivalent. However, whereas the metal valve was automatically provided with its own screen, the "GT" type will be unscreened. In some circuits instability may result unless a metal screen is slipped over the outside of the "GT" replacement and is connected to chassis. The circuit will then work as with the metal valve. If there is sufficient space, a "G" valve may also be inserted in place of its metal counterpart; but it has to be remembered that the "G" version is very much larger than the metal valve, and there may just not be enough room for it in some layouts. Again, a screening can may be required.

A "GT" valve can always be fitted in place of a "G" equivalent because it has the same electrical characteristics and is smaller in size. If the "G" valve had a screen, the "GT" valve will also need one, and the large screen provided for the "G" valve will normally suffice. A "G" valve can similarly replace a "GT" type, provided there is enough space for it. If a screen was fitted to the "GT" valve then a new, larger, one will be needed for the "G" equivalent.

Because it is smaller than the other two types, a metal valve can always be fitted in place of either the "G" or "GT" equivalent. There is, however, one point to look out for. If the valveholder was originally wired for a "G" or "GT" valve, it has to be remembered that the pin connecting to the envelope in the metal version will be blank with the glass valve. The appropriate valveholder tag might, in consequence, have been used as an anchor tag, with the result that the metal envelope of the new valve may not be at chassis potential. According to the vagaries of the person who planned the valveholder wiring, the metal envelope of the new valve might then be at r.f. potential, in which case instability could result, or it may even be at h.t. potential, whereupon you become the recipient of an unpleasant and unexpected shock. So it is worth while checking whether any connections other than to chassis are made to the screen pin tag before inserting metal valves in equipment which previously used glass equivalents. It is, in any case, good practice to connect the screen pin tag to chassis when using the metal valve, even if this

means that existing wiring to this tag has to be shifted.

So far as making up new items of equipment is concerned, these can be designed around metal and/or glass valves, as desired. It is preferable, for neatness, to avoid using "G" types with the metal and "GT" types. The "G" type is so much larger than the other two types that it tends to give the resultant chassis rather a ludicrous appearance. On the other hand, a chassis with mixed metal and "GT" types looks quite trim and smart. As also, of course, does a chassis with all "G" valves.

Range Of Metal Valves

I've referred to the 6K7 in describing metal valves and their equivalents because this is a well-known r.f. pentode in the "metal range". The initial "6" in the code indicates a nominal heater voltage of 6.3 (actually 5.6 to 6.6 volts). Other commonly met valves in the series, with "G" and "GT" equivalents, are the 6B8 (double-diode-pentode), 6J5 (medium- μ triode), 6K8 (triode-hexode frequency changer), 6L7 (pentagrid mixer), 6Q7 (double-diode-triode), 6V6 (beam tetrode output) and the 6F6 (pentode output). The 6B8, 6K8 and 6Q7 all have top cap connections, in company, as we have already seen, with the 6K7. Types 6SK7 and 6SQ7 are also in the range, these being very similar to the 6K7 and 6Q7 respectively, but with all connections brought out to the pins at the base. Further types are the 6SN7 and 6SL7 (both double-triodes), these also having all connections brought out to the pins at the base. Other metal types are the 5Y3 and 5Z4, these being full-wave h.t. rectifiers with 5 volt heaters. Also likely to be encountered are valves with 12.6 volt heaters, and in these the figure "12" replaces the "6" in the codes just discussed, viz: 12J5 instead of 6J5, 12K8 instead of 6K8, and so on.

Unfortunately, it isn't possible to state that all octal valves without the letters "G" or "GT" after the type number are metal types, because post-war American production went back to glass envelopes without, in many cases, bothering to employ "G", "GT" or any other suffix letter in the code to indicate a glass type.

What sort of home-built equipment can these metal valves and their "G" or "GT" equivalents be used in? One excellent line-up is for a long, medium and short

wave superhet, this consisting of a 6K8 frequency changer, a 6SK7 i.f. amplifier, a 6SQ7 double-diode-triode, a 6V6 output tetrode, and a 5Z4 h.t. rectifier. A record-player amplifier could use a 6J5 triode and a 6V6, or a 6SN7 double-triode and a 6V6. A very nice amplifier can employ a 6SN7 as voltage amplifier and phase splitter, followed by two 6V6's in push-pull. There are many other combinations which can similarly use these inexpensive valves, and they only suffer from the disadvantage that the valves are larger in size than those we normally, these days, play around with.

Tape Recording Index

If you are a keen tape recording enthusiast it is essential to keep a register of all the recordings you make. Otherwise, it becomes possible to forget the position taken up on a tape by a particularly important recording, whereupon a great deal of time is wasted in

searching through one or more tracks in search of it. Alternatively, and far worse, you may accidentally erase a highly prized recording by inadvertently running the tape through a second time.

All these eventualities may be guarded against, and a neat and reliable register of all recordings, whether they be temporary or permanent, can be obtained by taking advantage of the newly introduced Tape Recording Index (patent pending) manufactured and distributed by Thistleboon Enterprises Ltd., 13 Thistleboon Road, Mumbles, Swansea. This Index comprises a number of stiff cards fitted into a stout folder measuring $6\frac{1}{2} \times 8\frac{1}{2} \times \frac{3}{8}$ in when closed.

There are three sections (also called Indexes) in the complete Index. Index A comprises 16 cards (catering for 16 tracks) fitted in a series of pockets positioned above each other in such a manner that all entries may be seen at a glance, and it is intended for tapes that are constantly in use. Thus, empty

tapes, tapes before editing and tapes with non-permanent recordings may be identified, together with notes on the recordings made. Important recordings which will later be transferred to Index B can be marked by applying a stick-on red spot (supplied with the Index) to the appropriate card, thereby preventing accidental erasure.

Index B provides a record of permanent recordings, and caters for 56 tracks. Index C consists of a number of cards measuring 6×8 in and is intended for those recordings listed in Index B which require a detailed card index. Each card has spaces for the entry of such details as Title, Quality, Time, Counter, Speed, Mono/Stereo, Recording, Notes, and so on. Full details on any recording may be neatly entered on each of the cards in this Index.

Further information on the Tape Recording Index may be obtained from Thistleboon Enterprises, at the address given above.

Spectra Radio Spectacles

(3 Transistor—1 Diode—Micro Circuit Transistor Set)

The idea of radio spectacles was tried several years ago but met with little success. The component parts had not been sufficiently perfected to prevent making lengthy listening tiring and uncomfortable. Spectra radio spectacles are really a by-product of years of experimental work on a hearing aid. The result—a newly discovered miniature radio circuit, perfectly tuned and controlled, which cannot harm the ear after many hours of constant listening. It was then a short step from this technical discovery to the commercial development of the idea into something useful and valuable.

Powered by a tiny battery, giving between 80–160 hours of listening—a very good pick-up range, Spectra Radio Spectacles are not just a “gimmick”, but of great value and adaptability. The uses of Spectra are almost unlimited.

In places where the use of a transistor set is either prohibited or causes annoyance, such as at the beach or other public places, walking, riding, work or leisure, lying in bed or in hospital—there are so many situations where Spectra whiles away time pleasantly, but prevents one being a social nuisance.

Made under expert supervision, Spectra is a precision instrument, not a toy. The lenses are carefully ground, and being without parallax, cannot harm the eyes.

Spectra Radio Spectacles are available in two styles. Men's are in black and ladies have a choice of four colours. For use as normal spectacles an optician will fit prescription lenses at purchasers' cost.

Sole Distributors: Dragon Wire Products, Spring Road, Spon Lane, Smethwick, Birmingham.

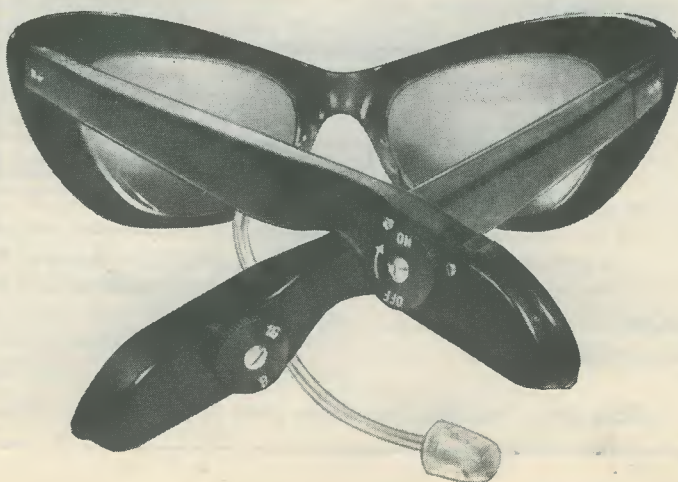

LEARN ELECTRONICS AS YOU BUILD 25 CIRCUITS . . . EXPERIMENTS . . . TEST GEAR . . .

including

● CATHODE RAY OSCILLOSCOPE

- VALVE EXPERIMENTS
 - BASIC AMPLIFIER
 - BASIC RECTIFIER
 - PHOTO ELECTRIC CIRCUIT
 - TIME DELAY CIRCUIT
- SQUARE WAVE GENERATOR
 - SIMPLE TRANSMITTER
 - TRANSISTOR EXPERIMENTS
 - BASIC OSCILLATOR
 - ELECTRONIC SWITCH
- SIGNAL TRACER
 - BASIC COMPUTER CIRCUIT
 - BASIC RADIO RECEIVER
 - MORSE CODE OSCILLATOR ETC. ETC.

This complete practical course will teach you all the basic facts of electronics by making experiments and building apparatus. You learn how to recognise and handle all types of components—their symbols and how to read a circuit diagram. You see how circuits are built and how they work **BY USING THE OSCILLOSCOPE PROVIDED**. Applications of all the main electronic circuits are

demonstrated—radio reception and transmission; photo-electrics; computer basics; timers; control circuits; etc.; including servicing techniques. **NO MATHS USED OR NEEDED. NO THEORY NEEDED. NO PREVIOUS KNOWLEDGE OR EXPERIENCE NEEDED.** Tutor service available. No extras needed—tools provided. Send now, for *Free Details* without obligation, to address below

To **RADIOSTRUCTOR**, Dept. K3, READING, BERKS. *Please send free details of your electronics kit set to:*

POST NOW



NAME _____
ADDRESS _____

SMALL ADVERTISEMENTS

Use this form for your small advertisement

To: **The Advertisement Manager, Data Publications Ltd., 57 Maida Vale, London, W.9**
Please insert the following advertisement in the _____ issue of **THE RADIO CONSTRUCTOR**

16 words at 9d.
= 12/-

**ALL WORDING
IN
BLOCK LETTERS
PLEASE**

I enclose remittance of _____ being payment at 9d. a word. **MINIMUM 12/-.**
Box Number, if required, 2/- extra.

NAME _____
ADDRESS _____

Copy to be received four weeks prior to publication. Published on the 1st of every month

THE RADIO CONSTRUCTOR

Price 2/3 monthly, postage 6d.

Published on the first of each month for the practical radio enthusiast. Articles cover Receivers, Televisors, Test Gear, Aerials, Amplifiers, Intercoms, Recording Equipment, Radio Control of Models, Workshop Practice, Transistor Techniques, etc.

DATA BOOKS SERIES

DB5 TV Fault Finding

96 pages. Price 6/-, postage 6d.

Profusely illustrated with photographs taken from a television screen depicting the faults under discussion and containing a wealth of technical information, with circuits, enabling those faults to be eradicated.

Covers both B.B.C. and I.T.A.

"... A book that should be in every television dealer's service workshop, and in every home-constructor's, for that matter."—*Journal of the Television Society*.

DB6 The Radio Amateur Operator's Handbook

64 pages. Price 5/-, postage 6d.

Contains Amateur Prefixes, Radio Zone Boundaries, Amateur Band Frequency Allocations, Call Areas, Charts and Maps, Areas, Codes, Mileage Tables, Prefixes/Directional Bearings, Post Office Regulations, and much other useful operating data. For the beginner there are notes on how to use the mass of information given to obtain the greatest satisfaction from the hobby.

"... For concise knowledge in this field a few shillings well worth spending."—*Electronics* (Australia).

DB14 Short Wave Receivers for the Beginner

72 pages. Price 6/-, postage 5d.

Contains a selection of both battery and mains operated short wave receivers, circuits, point-to-point wiring diagrams and many illustrations. Introductory chapter gives much information on the Short Wave Spectrum, Clubs, QSL'ing, Aerials, Amateur and Broadcast Band Listening, Frequencies, etc.

This book has been specially prepared for the beginner interested in short wave receiver construction and operation.

DB15 Twenty Suggested Circuits

48 pages. Price 3/6, postage 4d.

By G. A. French. Covers subjects ranging from electronic laboratory equipment to the simplest of periodic switches. Includes: simple and inexpensive two-valve capacity bridge, short wave regeneration preselector, one-valve speech operated switching circuit, transformer ratio analyser, series noise limiter, receiver remote mains on-off control, and many other circuits.

DB16 Radio Control for Models

192 pages. Price 15/-, postage 9d.

By F. C. Judd. Contains both theory and practical designs of simple and advanced transmitters and receivers; basic concepts, aerials, uses of radio components, transistorised receivers, multi-channel operation, etc. Sections on servo-mechanisms by Raymond F. Stock.

More than 200 illustrations. Circuits, photographs, tables and working diagrams.

DB17 Understanding Television

512 pages. Price 37/6, postage 2/6

By J. R. Davies. This book, which deals with the principles of 625 line reception as fully as 405 line reception, fully explains: the nature of the television signal; the cathode ray tube; receiver tuner units; receiver i.f. amplifiers; a.f. and video amplifiers; vertical and horizontal timebases; deflector coil assemblies; synchronising; automatic gain and contrast control; power supplies and receiver aerials. Also includes a comprehensive introduction to colour television.

"... one of the best books that aims to explain television in simple language...". R.S.G.B. Bulletin.

PANEL-SIGNS TRANSFERS

Set 3 Wording—White. Wording for Receivers, Amplifiers, Transmitters, Test Equipment and other Radio Apparatus. (Also 2 Safety Notices—white wording on red background) 6 sheets, over 1,000 words and symbols.

Set 4 Wording—Black. As in set 3. (Safety Notices have black wording on red background.)

Set 5 Dials. 6 sheets containing one Large and two Medium scales, Large Horizontal Tuning scale, Frequencies, 12 Control Panels (white markings, no background).

Set 6 Dials. As in set 5, but Control Panels have black background.

Price per set 4/6, postage 4d.

Order Form overleaf

ORDER FORM

TITLE	No.	£	s.	d.
<p>THE RADIO CONSTRUCTOR Price 2/3 each, postage 6d. Issue(s) required</p> <p>..... Annual subscription commencing with..... issue Price 33/-, post free</p> <p><i>Bound volumes:</i> Vol. 18. August 1964 to July 1965 Price 30/-, postage 3/6</p> <p>DATA BOOKS SERIES</p> <p>DB5 TV Fault Finding 96 pages. Price 6/-, postage 6d.</p> <p>DB6 The Radio Amateur Operator's Handbook 64 pages. Price 5/-, postage 5d.</p> <p>DB14 Short Wave Receivers for the Beginner 72 pages. Price 6/-, postage 5d.</p> <p>DB15 Twenty Suggested Circuits 48 pages. Price 3/6, postage 5d.</p> <p>DB16 Radio Control for Models 192 pages. Price 15/-, postage 9d.</p> <p>DB17 Understanding Television 512 pages. Price 37/6, postage 2/6</p> <p>PANEL-SIGNS TRANSFERS Six sheets in each set Set 3: Wording — White Set 4: Wording — Black Set 5: Dials — Control Panels have a clear background Set 6: Dials — Control Panels have a black background Price per set 4/6, postage 4d.</p>				

£ : :

*Please send cash with order, regret no C.O.D.
 Overseas customers please pay by International Money Order*

NAME

ADDRESS

(Please use Block Capitals for both name and address)

All publications are obtainable from your local bookseller or direct from
Data Publications Ltd 57 Maida Vale London W9

For full details see overleaf

SMALL ADVERTISEMENTS

Rate: 9d. per word. Minimum charge 12/-.
Box No. 2/- extra.

Advertisements must be prepaid and all copy must be received by the 4th of the month for insertion in the following month's issue. The Publishers cannot be held liable in any way for printing errors or omissions, nor can they accept responsibility for the *bona fides* of advertisers. (Replies to Box numbers should be addressed to: Box No. —, *The Radio Constructor*, 57 Maida Vale, London, W.9.)

THE INCORPORATED PRACTITIONERS IN RADIO AND ELECTRONICS (I.P.R.E.) LTD.
Membership conditions booklet 1s. Sample copy of I.P.R.E. Official Journal 2s. post free.—Secretary, Dept. D, 32 Kidmore Road, Caversham, Reading, Berkshire.

SERVICE SHEETS, 1925-1965. From 1s. Catalogue 6,000 models, 1s. 6d. S.A.E. enquiries.—Hamilton Radio, 13 Western Road, St. Leonards, Sussex.

HAMMER FINISH PAINT. The modern finish for electronics. Can be BRUSHED or sprayed. Blue or Silver. 2½ oz tins 3s. 6d., post 8d., ½ pint 7s. 6d., post 1s. 9d., 1 pint 15s., post 2s. 9d. Orders over 30s. post free. Retailers supplied. Write for details. Amazing results! Return of post service.—Finnigan Speciality Paints (RC), Mickley Square, Stockfield, Northumberland.

GOVERNMENT SURPLUS electrical and radio equipment. Our new catalogue No. 16 ready now, 2s. 6d. post free, cost refunded on purchase of goods over £2.—Arthur Sallis Radio Control Ltd., 93 North Road, Brighton, Sussex.

MULLARD TRANSISTORS & DIODES. OC45, OC71, OC76, OC81, OC81D, OC84, 3s. OC75, OC170, AF114, AF115, AF116, 3s. 6d. OC81, OC84 pairs, 6s. OC28, OC35, 7s. 6d. OA70, OA79, OA81, 1s. 3d. BY100, 7s. 6d. Texas 2G344a, 3s. 2G339 (=AC127), 4s. 6d. IS100, 2s. 3d. MA393, 3s. 6d. GJ5.d, 2s. 3d. ZT20, 6s. IN69, 2s. AF139, 18s. 6d. All post paid.—Radio Constructor's Centre, 363 Westborough Road, Westcliff-on-Sea, Essex.

FOR SALE. Teleprinters, perforators, reperforators, auto-transmitters, signalling rectifiers, etc., from £5 for personal callers.—W. Batey & Co. (Exports) Ltd., 77 Akeman Street, Tring, Herts. Ring Tring 3476/8.

CONVERT ANY TV SET INTO AN OSCILLOSCOPE. Instructions and diagrams, 12s. 6d.—Redmond, 42 Dean Close, Portslade, Sussex.

TELEVISION SETS FROM 35/-, not working, 20 for 25/- each. Callers only.—20 Palmerstone Road, Earley, Reading, Berks.

continued on page 141

BENTLEY ACOUSTIC CORPORATION LTD

38 CHALCOT ROAD CHALK FARM LONDON NW1
THE VALVE SPECIALISTS Telephone PRIMROSE 9090

IL4	2/3	6/30L2	8/9	DAF96	6/-	EF37A	7/-	EZ81	4/3	U25	8/6
IR5	4/-	10C1	9/9	DF96	6/-	EF41	6/6	HAB80	9/3	U26	7/6
IS4	5/-	10C2	12/-	DK92	8/-	EF80	4/3	KT66	12/3	U31	6/6
IS5	3/3	10F1	10/-	DK96	6/6	EF83	9/9	N339	25/-	U191	9/6
IT4	2/3	10F18	9/9	DL96	6/-	EF85	4/6	PAC80	6/9	U282	12/3
2D21	5/-	10LD11	9/6	DM70	5/-	EF86	6/6	PC86	9/9	U301	11/-
3D6	3/9	10P13	12/-	DY86	6/6	EF89	4/-	PC88	9/-	U329	9/-
3Q4	5/3	10P14	11/6	DY87	7/6	EF91	3/-	PC95	6/9	U404	6/-
3Q5	6/9	12AH8	10/9	EBBCC	10/-	EF92	2/6	PC97	6/9	U801	15/-
3S4	4/9	12AT6	4/6	EAC80	5/9	EF97	9/9	PC85	5/6	UABC80	5/-
3V4	5/-	12AU6	5/9	EAF42	7/9	EF98	7/3	PC88	10/6	UAF42	6/3
5Y3GT	4/9	12AV6	5/9	EB91	2/3	EF183	7/3	PC88	10/6	UBC41	6/3
5Z4	7/6	12BA6	5/3	EBC33	6/-	EF184	6/6	PCC89	11/6	UCB81	6/3
6AQ5	5/9	12BE6	4/9	EBC41	6/6	EL33	6/6	PCC189	10/-	UBF80	5/6
6AT6	3/6	12BH7	6/-	EBC81	5/9	EL34	9/9	PCF80	6/6	UBF89	6/3
6AU6	5/9	12AQ5	7/3	EBF80	5/9	EL36	8/9	PCF82	6/-	UBL21	10/9
6AV6	5/6	20D1	10/-	EBF83	4/6	EL41	7/-	PCF84	8/6	UC92	6/3
6BA6	4/6	20F2	11/6	EBF89	5/9	EL42	7/9	PCF86	8/6	UC84	8/-
6BE6	4/3	20L1	12/-	EBL21	10/3	EL83	6/9	PCF801	10/-	UCC85	6/6
6BH6	5/3	20P1	12/6	EC92	6/6	EL84	4/6	PCF802	10/-	UCF80	8/3
6Bj6	5/6	20P3	12/-	ECC81	3/6	EL85	7/6	PCL82	6/6	UCH21	8/-
6BQ7A	7/6	20P4	13/-	ECC82	4/6	EL86	7/3	PCL83	9/6	UCH42	8/-
6BR7	8/3	20P5	11/6	ECC83	4/6	EL95	5/-	PCL84	7/6	UCH81	6/6
6BW6	7/6	30C15	10/-	ECC84	5/6	EL80	13/6	PCL85	8/6	UCL82	7/3
6CD6G	18/-	30C17	11/9	ECC85	5/9	EM34	11/6	PCL86	8/9	UCL83	9/3
6CH6	6/6	30C18	9/3	ECC88	8/9	EM71	15/6	PL36	9/-	UF41	6/9
6F1	9/6	30F5	7/3	ECC189	11/6	EM80	6/3	PL38	16/-	UF42	4/9
6F7G	4/6	30FL1	9/3	ECC80	7/3	EM81	7/-	PL81	6/9	UF80	6/3
6K7G	1/3	30L15	10/3	ECC82	6/3	EM84	6/-	PL82	5/-	UF85	6/9
6K8G	3/3	30L17	11/6	ECCF86	11/6	EM85	8/9	PL83	6/-	UF86	9/-
6L1	10/-	30P12	7/6	ECH21	9/-	EM87	7/6	PL84	6/3	UF89	5/6
6L6GT	7/3	30P19	12/-	ECH35	6/-	EY51	5/6	PM84	9/3	UL41	7/-
6L18	10/-	30PL1	9/3	ECH42	8/-	EY81	7/3	PY33	8/9	UL84	5/6
6LD20	6/6	30PL13	10/6	ECH81	5/9	EY83	9/3	PY80	4/9	UM80	8/3
6Q7G	4/-	30PL14	11/3	ECH83	6/6	EY84	9/6	PY81	5/-	UY21	7/9
6S17	4/9	30PL15	9/6	ECH84	9/6	EY86	5/6	PY82	4/9	UY41	5/-
6S7L	4/6	35V4	4/6	ECL80	5/9	EY88	8/9	PY83	5/6	UY85	4/9
6V6G	3/6	85A2	6/6	ECL82	6/6	EZ40	5/3	PY88	7/3	VP4B	12/-
6X4	3/9	5763	7/6	ECL83	8/9	EZ41	6/3	PY800	5/9	X41	10/-
6X5	5/3	AZ31	9/6	ECL86	8/-	EZ80	3/9	PY801	7/6	X78	26/2

Terms of business: Cash with order or C.O.D. only. Post/packing 6d. per item. Orders over £5 post free. C.O.D. 3/6 extra. All orders despatched same day. Complete catalogue including transistor section and components with terms of business 6d. Any parcel insured against damage in transit for 6d. extra. We are open for personal shoppers 9 a.m.—5 p.m. Saturdays 9 a.m.—1 p.m.

JACKSON

the big name in **PRECISION** components

Precision built radio components are an important contribution to the radio and communications industry.

SL 16 DRIVE

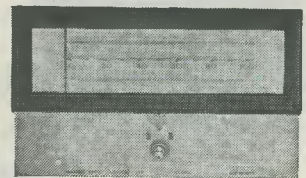

A general purpose slide rule Drive for F.M./V.H.F. Units, short-wave converters, etc. Printed in two colours on aluminium, with a 0-100 scale and provision is made for individual calibrations. Complete with bronze escutcheon and glass. 15/-.

It's reliable if it's made by JACKSON!

MADE IN ENGLAND

JACKSON BROS. (LONDON) LTD.

Dept. R.C., Kingsway-Waddon, Croydon, Surrey
Telephone Croydon 2754-5
Telegrams Walfilco, Souphone, London



SPECTRA RADIO SUNGLASSES

NEW sensational achievement in the field of electronics

Here's the latest, greatest idea of all. Sunglasses with a built-in transistor radio. They're light. They're stylish. They're Spectra radio sunglasses. The battery is no bigger than a sixpence but it gives you over 100 hours' listening—and it's replaceable at all leading chemists. Spectra radio sunglasses are available in two styles, black for men and decorative imitation pearl in white, gold, pink/gold and brown for ladies. Only £5.19.6 plus 4/6 postage and packing. Send cash with order to:—

The medium price ensures a great demand. Send for details NOW!

MONEY BACK GUARANTEE

Dragon Wire Products Ltd. SPRING ROAD, SPON LANE, SMETHWICK, BIRMINGHAM 40

AMATEUR RADIO
CHAS. H. YOUNG LTD.

MIDLAND AGENTS FOR

- ★ EDDYSTONE RECEIVERS & COMPONENTS
- ★ NATIONAL RECEIVERS & TRANSCEIVERS
- ★ GREEN & DAVIS EQUIPMENT
- ★ KW EQUIPMENT
- ★ MOSLEY AERIALS
- ★ WITHERS
- H.P. FACILITIES AVAILABLE
- PART EXCHANGES

AERIAL EQUIPMENT

TWIN FEEDER. 300 ohm twin ribbon feeder similar K25, 6d. per yard. 75 ohm twin feeder, 6d. per yard. Post on above feeders and cable, 2/- any length.

COPPER WIRE, 14G, H/D, 140ft, 22/6; 70ft, 11/6. Post and packing 3/-. Other lengths pro rata.

FEEDER SPREADERS. 6" Ceramic type F.S., 10d. each. Postage 2/- up to 12.

CERAMIC CENTRE PIECE for dipoles, Type AT, 1/6 each. P. & P. 1/6.

2 METRE BEAM, 5 ELEMENT W.S. YAGI. Complete in box with 1" to 2 1/2" masthead bracket. Price 49/-. P. & P. 4/-.

SUPER AERAXIAL, 70/80 ohm coax, 300 watt very low loss, 1/8 per yard. 50 ohm 300 watt, 1/9 per yard. P. & P. 2/6.

TOUGH POLYTHENE LINE, type MLI (100lb), 2d. per yd. or 12/6 per 100 yds. Type ML2 (220lb), 4d. per yd. or 25/- per 100 yds., ML4 (400lb), 6d. per yd. Ideal for Guys, L.W. Supports, Halyards, etc. Postage 1/-.

ABSORPTION WAVEMETERS. 3.00 to 35.00 Mc/s in 3 Switched Bands. 3.5, 7, 14, 21 and 28 Mc/s. Ham Bands marked on scale. Complete with indicator bulb. A MUST for any Ham Shack. ONLY 25/- EACH. Post free.

BANDCHECKER MONITOR, 3.00-35.00 Mc/s in 3 switched Bands. 0-1mA Indicator. Monitor Socket. Very sensitive, £3.13.6. P. & P. 3/-.

VARIABLE CONDENSERS. All brass with ceramic end plates and ball race bearings. 50pF, 5/9; 100, 6/6; 160, 7/6; 240, 8/6; and 300pF, 9/6. Extension for ganging. P. & P. 1/6.

RACK MOUNTING PANELS: 19" x 5 1/2", 7", 8 1/2", or 10 1/2", black crackle finish, 5/9; 6/6, 7/6, 9/- respectively. P. & P. 3/-.

GELOSO VFO UNITS. 4/102 with new dial and escutcheon. Outputs on 80, 40, 20, 15 and 10. For 2-807 or 6146 Tubes. Only £8.15.0, 3 valves to suit, 24/- ALL POST FREE.

30 WATT MOD. TRANS. 2 x 807 mod. to 807 R.F. Few only, 18/6 each. P. & P. 3/6.

2 METRE BEAM, 5 ELEMENT W.S. YAGI. Complete in box with 1" to 2 1/2" masthead bracket. Price 49/-. P. & P. 4/-.

CHAS. H. YOUNG LTD
170-172 Corporation St., Birmingham 4

Please print your address. No C.O.D. under £1. 'phone CEN 1635

SMALL ADVERTISEMENTS

continued from page 139

"MOBILE NEWS" pays £2 per thousand words for technical articles of amateur mobile interest. Submit to—Honorary Editors, Amateur Radio Mobile Society, 95 Collinwood Gardens, Clayhall, Ilford, Essex.

FOR SALE. Heathkit Balun coil unit Model B-1U, £3. Postage extra.—Box No. F236.

BOOKS TO CLEAR: *Frequency Modulated Radio*, 1956 (Sturley), 5s.; *Testing Radio Sets*, 5th edition (Reyner), 7s. 6d.; *Transmitting Valves*, 1951 (Heyboer & Zijlstra), 10s.; *High Fidelity Sound Reproduction*, (Molloy), 7s. 6d.; *How to Install & Service Auto Radios*, 1959 (Darr), 7s. 6d.; *Introduction to TV Servicing*, (Swalum & Van der Woerd), 10s.; *Television Receiver Design*, 1953 (Neeteson), 7s. 6d.; *Radio Operating*, 8th edition (Nilson & Hornung), 5s.; *Television Viewers' Handbook*, 1954 (Armstrong), 3s. All at less than half price.—Box No. F238.

FOR SALE. Labgear LG 300 transmitter unit, VFO section converted for RTTY FSK. This makes an excellent RTTY Tx. Owner only selling as converting SSB rig for RTTY. £25 o.n.o. Plus carriage.—Box No. F239

FOR SALE. Heathkit valve millivoltmeter, model AV-3U. Unused. £15.—Box No. F240.

FOR SALE—VALVES. DL92, EB91, EF92, IT4 at 1s. 6d. ECC82, EL91 at 3s. CV1075, U14, VR91, VT136, 955, 6AT6 at 5s. EF40, 801, 830B, T20 at 7s. 6d.—Box No. F241.

FOR SALE. Small domestic broadcast receiver, K.B. Minuet, red plastic case, cream dial. £5 plus postage.—Box No. F242.

FOR SALE. Creeds teleprinter No. 3 with matching Westinghouse power rectifiers. Both items £5. Carriage paid. Brown Bouverie voltage regulator. Brand New. Cost £300. Any offer considered.—Box No. F243.

YOUR KITS EXPERTLY BUILT. Mains, battery radios of every description. S.A.E. enquiries.—W. Thomas, 106 Wynnville, Ruabon, Nr. Wrexham, Denbighshire.

WANTED. December 1963 copy of *The Radio Constructor*. Cover price and postage paid.—Box No. F245.

TECHNICAL DRAWINGS, Artwork, etc. Electronic and Radio Circuits a speciality. Modest charges.—B. P. Meaney, 43 Forest Road, Worthing, Sussex.

INTERESTED IN AMATEUR RADIO TELEPRINTING? Then join the British Amateur Radio Teleprinter Group. Details from Hon. Sec., G3LLV, 15 Havelock Square, Broomhill, Sheffield 10.

"MEDIUM WAVE NEWS" Monthly during DX season—Details from: B. J. C. Brown, 60 White Street, Derby.

continued on page 143



FIRST QUALITY PVC TAPE

5½" Std. 850ft	9/-	5" L.P. 850ft	10/6
7" Std. 1200ft	11/6	3" T.P. 600ft	8/-
3" L.P. 240ft	4/-	5" T.P. 1800ft	20/6
5½" L.P. 1200ft	11/6	5½" T.P. 2400ft	27/6
7" L.P. 1800ft	18/6	7" T.P. 3600ft	37/6

P. & P. on each 1/6, 4 or more post free.

Complete with McLaren Variable Thermostat 90° to 180°F. 20 amp. A.C. and GEC double pole 20 amp. mains switch. 18", 30" and 36". State length required. £2.0.0, plus 5/- P. & P.

3kW IMMERSION HEATER

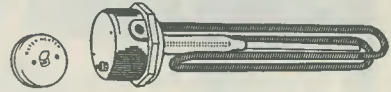

"PREMIER" KETTLE ELEMENT

1000W, 8/6 plus 3/- P. & P. Retaining nut and flange 2/6, switch plug to suit 2/6.

A.C. MAINS MOTOR



Can be used for a variety of purposes, silent running, satisfactory in every way. 230/250V A.C. 9/6. P. & P. 3/-.

3 to 4 WATT AMPLIFIER KIT

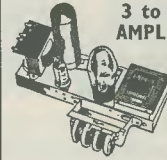

comprising chassis 8½" x 2½" x 1". Double wound mains transformer,

output transformer, volume and tone controls, resistors, condensers, etc. 6V6, ECC81 and metal rectifier. Circuit 1/6 free with kit. 29/6, plus 4/6 P. & P.



40W FLUORESCENT LIGHT KIT

incorporating GEC Choke size 8½" x 1½" x 1½", 2 bi-pin holders, starter and starter holder, 11/6. P. & P. 4/6.

Similar to above: 80W Fluorescent Light Kit incorporating GEC choke size 11½" x 1½" x 1½", 2 bi-pin holders, starter and starter holder, 17/6. P. & P. 5/6.

8-watt 5-valve PUSH-PULL AMPLIFIER & METAL RECTIFIER

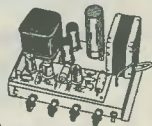

Size: 9" x 6" x 1½" A.C. Mains 200-250V 5 valves. For use with Std. or L.P. records, musical instruments, all makes of pick-ups and mikes. Output 8 watts at 5 per cent total distortion. Separate bass and treble lift controls. Two inputs, with controls, for gram. and mike. Output Transformer tapped for 3 and 15 ohms speech coils. Built and tested. £3.19 6. P. & P. 8/-.

SPECIAL OFFER: POWER SUPPLY KIT to purchasers of Elegant Seven parts, incorporating mains transformer, etc. A.C. mains 200-250V. Output 9V 100mA. 7/6.

'ELEGANT SEVEN' Mk. II

Combined Portable and Car Radio The Radio with the "Star" Features

- ★ 7-transistor superhet. Output 350mW.
- ★ Grey wooden cabinet, fitted handle with silver coloured fittings. Size 12½" x 8½" x 3½"
- ★ Horizontal tuning scale, size 11¼" x 2½" in silver and black lettering.
- ★ All stations clearly marked.
- ★ Ferrite-rod internal aerial.
- ★ I.F. Neutralisation on each stage. 460 kc/s.
- ★ D.C. coupled output stage with separate A.C. negative feed back.
- ★ All components, ferrite rod and tuning assembly mounted on printed board. ★ Operated from PP9 battery. ★ Full comprehensive instructions and point-to-point wiring diagrams. ★ Printed circuit board, back printed with all component values. ★ Fully tunable over medium and long waveband. ★ Car aerial socket.
- ★ Full after-sale service. 4" SPEAKER.

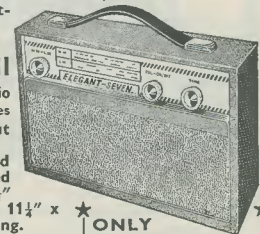

ONLY
£4.4.0

Plus 6/6 Post & Packing

Parts list and circuit diagram 2/6, FREE with parts.

Shop Hours 9 a.m.-6 p.m. Early Closing Wednesday Goods not despatched outside U.K. All enquiries S.A.E. Terms C.W.O.

RADIO & TV COMPONENTS (ACTON) LTD.
21F High St., Acton, London, W.3

LATEST HIGH QUALITY COMPONENTS FROM THE MAXI-Q RANGE . . .

TESTED AND TRIED OVER 5 FREQUENCY RANGES

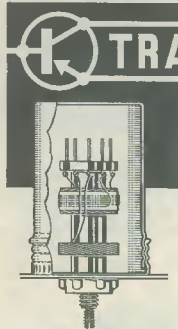

TRANSISTOR TUNING COILS

Coils for transistor superhets or converters, with or without an R.F. stage and using 465 kc/s or 1.6 Mc/s I.F.

- ★ Noval B9A Based for Plug-in application—Screw threaded for Chassis application.
- ★ Formers moulded in low-loss polystyrene for best results.
- ★ Each coil is packed in an aluminium container which may be used as a screening can.
- ★ Brass threaded adjustable iron-dust cores.

The following colour code identifies the coils:

BLUE—Aerial coil with base input winding.

YELLOW—Interstage R.F. coil with couplings.

RED—Oscillator coil for 465 kc/s I.F.

WHITE—Oscillator coil for 1.6 Mc/s I.F.

PRICE 4/9 each. Plus 6d. Postage.

Coverages: Range 1T—15/4 Mc/s; 2T—.515/1.545 Mc/s; 3T—1.67/5.3 Mc/s; 4T—5/15 Mc/s; 5T—10.5/31.5 Mc/s.
Full technical details now included in Technical Bulletin DTB.4—2/-.

IFT.13 Miniature 465 kc/s I.F. Transformer .. 7/6d. each

GENERAL CATALOGUE covering full

IFT.14 Miniature 465 kc/s Last I.F. Transformer 7/6d. each

range of components send 2/- in stamps.

IFT.16 Miniature 1.6 Mc/s I.F. Transformer .. 6/6d. each

PLEASE SEND S.A.E. WITH ALL

IFT.17 Miniature 1.6 Mc/s Last I.F. Transformer 6/6d. each

OTHER ENQUIRIES.

DENCO (CLACTON) LTD · (DEPT. R.C.) · 357/9 Old Road · Clacton-on-Sea · Essex

Any holes in your knowledge of TRANSISTORS?

Whatever your interest in transistor circuitry, you will find the Mullard "Reference Manual of Transistor Circuits" and "Transistor Radios—Circuitry and Servicing", valuable sources of reference.

The former describes more than sixty circuits for both domestic and industrial applications.

The latter is an introduction to the subject and describes the basic properties of semiconductors, their function, elementary circuitry and servicing.

REFERENCE
MANUAL OF
TRANSISTOR
CIRCUITS
U.K. PRICE
12/6
Post extra 1/-

TRANSISTOR
RADIOS
Circuitry and
Servicing
U.K. PRICE
5/-
Post extra 6d.



Get your copies from your radio dealer, or send remittance with order to:

MULLARD LTD · MULLARD HOUSE · TORRINGTON PLACE · LONDON WC1

TESTED TRANSISTORS

1/- each Red or White Spots. 10/- per doz.

2/- each XA101, XA102, XA111, XA112, XB103, NKT122, 2E1, OA70, OA90, OC430.

3/- each OC44, OC45, OC70, OC71, OC81, OC81D, OC82, OC82D, OC169, OC200.

4/- each AF114, AF115, AF116, AF117, XA103, XB102, XC121, XU611, OC170, OC171.

5/- each OC72, OC139, OC204, ORP60, XC141, BY100, ACY22, GET8, AFZ11, AFZ12.

10/- each OC22, OC26, OC28, OC35, ORP12, AFY19, GET571, BFY17, BSY26, BSY29.

ZENER DIODES 4.7 volt to 30 volt $\frac{1}{4}$ watt, 3/6 each, 1.5 watt, 5/- each, 7 watt, 6/- each.

Plus lots not listed—i.e. S.C.R.'s, V.H.F. and N.P.N.'s.
Send 6d. stamp for Full Lists and Equivalent Chart.

B. W. CURSONS

78 BROAD STREET, CANTERBURY, KENT

SMALL ADVERTISEMENTS

continued from page 141

ARE YOU A MOTORING ENTHUSIAST? The Seven Fifty Motor Club caters for all types of motor sport—racing, rallies, hill climbs, etc. Monthly Bulletin free to members. For full details write to: The General Secretary, Colin Peck, "Dancer's End", St. Winifred's Road, Biggin Hill, Kent.

JOIN THE INTERNATIONAL S.W. LEAGUE. Free Services to members including Q.S.L. Bureau. Amateur and Broadcast Translation. Technical and Identification Dept.—both Broadcast and Fixed Stations, DX Certificates, contests and activities for the SWL and transmitting members. Monthly magazine, *Monitor*, containing articles of general interest to Broadcast and Amateur SWLs, Transmitter Section and League affairs, etc. League supplies such as badges, headed notepaper and envelopes. QSL cards, etc., are available at reasonable cost. Send for League particulars. Membership including monthly magazine, etc., 35s. per annum.—Secretary, ISWL, 12 Gladwell Road, London, N.8.

POSTAL ADVERTISING? This is the Holborn service. Mailing lists, addressing, enclosing, wrapping, facsimile letters, automatic typing, copy service, campaign planning, design and artwork, printing and stationery. Please ask for price list.—The Holborn Direct Mail Company, Telephone: TERminus 0588.

SITUATION VACANT

A FULL TIME TECHNICAL EXPERIENCED SALESMAN required for retail sales.—Write giving full details of age, previous experience and salary to: The Manager, Henry's Radio Ltd., 303 Edgware Road, London, W.2.

SITUATION WANTED

RADIO REPAIRMAN. Age 21. Radio work and salesmanship. Speaks French. Good experience. Wants job in Great Britain. Write to—Lo Quun Chong, Ritz Bar, Curepipe, Mauritius.

YOUR CAREER IN RADIO?

Big opportunities and big money await the qualified man in every field of Electronics today—both in the U.K. and throughout the world. We offer the finest home study training for all subjects in radio, television, etc., especially for the **CITY & GUILDS EXAMS** (Technicians' Certificates); the Grad. Brit. I.R.E. Exam.; the **RADIO AMATEUR'S LICENCE**; P.M.G. Certificates; the R.T.E.B. Servicing Certificates; etc. Also courses in Television; Transistors; Radar; Computers; Servo-mechanisms; Mathematics and Practical Transistor Radio course with equipment. We have **OVER 20 YEARS'** experience in teaching radio subjects and an unbroken record of exam. successes. We are the only privately run British home study Institute specialising in electronic subjects only. Full details will be gladly sent without any obligation.

SEND FOR FREE BROCHURE TO:

BRITISH NATIONAL RADIO SCHOOL
DEPT 4, RADIO HOUSE · READING · BERKSHIRE



ESTABLISHED

1865

Savings in this old established Building Society combine sound investment with an attractive return

THE DUCHESS OF KENT PERMANENT BUILDING SOCIETY

Member of the Building Societies Association

Shares are in units of £25 each (maximum investment £5,000) . . . **BUT, for the smaller saver**, Subscription Share accounts may be opened with any sum from 1/- upwards. Interest is payable half-yearly on Fully Paid Shares—credited annually on Subscription Shares—all interest accrues monthly

Withdrawals at short notice

INTEREST IS AT 4% PER ANNUM

(There is NO DEDUCTION FOR INCOME TAX, as this is paid by the Society)

For further information apply to

**DUCHESS OF KENT
PERMANENT BUILDING SOCIETY**
103 Cannon Street London EC4
Telephone MANSion House 8011

Please send to me, without obligation, free brochure and a copy of the audited statement of accounts. (I understand that I shall not be troubled with calls by representatives)

Name

(If lady, please state Mrs. or Miss)

Address

R.C.

(Please use Block Capitals for both name and address)

CHASSIS and CASES by



287/9 Edgware Road
London W2
TELEPHONE
PADDINGTON 5891/7595

BLANK CHASSIS—Same Day Service

Of over 20 different forms made up to YOUR SIZE.
(Maximum length 35", depth 4".)

SEND FOR ILLUSTRATED LEAFLETS

or order straight away, working out total area of material required and referring to table below which is for four-sided chassis in 16 s.w.g. aluminium.

48 sq. in.	4/3	176 sq. in.	9/-	304 sq. in.	13/6
80 sq. in.	5/6	208 sq. in.	10/-	336 sq. in.	14/9
112 sq. in.	6/6	240 sq. in.	11/3	368 sq. in.	15/9
144 sq. in.	7/9	272 sq. in.	12/6	and pro rata	
P. & P. 3/-		P. & P. 3/6		P. & P. 4/-	

Discounts for quantities. More than 20 different sizes kept in stock for callers.

FLANGES (1/4" or 3/8"), 6d. per bend.
STRENGTHENED CORNERS, 1/- each corner.

PANELS
Any size up to 3ft at 5/3 sq. ft. 16 s.w.g. (18 s.w.g. 4/6).
Plus postage and packing

CASES

ALUMINIUM, SILVER HAMMERED FINISH

Type	Size	Price	Type	Size	Price
U	4 x 4 x 4"	10/-	Y	8 x 6 x 6"	24/6
U	5 1/2 x 4 1/2 x 4 1/2"	15/-	Y	12 x 7 x 7"	41/-
U	8 x 6 x 6"	21/-	Y	13 x 7 x 9"	46/-
U	15 x 9 x 9"	44/6	Y	15 x 9 x 7"	48/6
W	8 x 6 x 6"	21/-	Z	17 x 10 x 9"	66/-
W	12 x 7 x 7"	34/-	Z	19 x 10 x 8 1/2"	71/-
W	15 x 9 x 8"	44/-	* Height		

Type Z has removable back and front panels.
Type Y all-screwed construction.

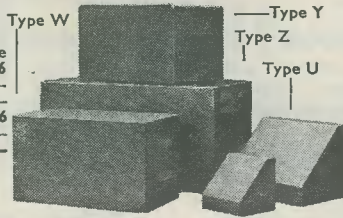

NYLON P.T.F.E.

ROD BAR SHEET TUBE STRIP WIRE

No quantity too small List on application

BRASS COPPER BRONZE ALUMINIUM LIGHT ALLOYS
STAINLESS STEEL

H. ROLLET & CO LTD

HOWIE STREET, LONDON, S.W.11 BATTERSEA 7872
Also at Liverpool, Birmingham, Manchester, Leeds, Glasgow

the unique **PANL** black crackle paint

4/-d. per 1/8 pt. Can

(We regret we can only supply on cash with order basis)

BRUCE MILLER LTD.,

249 Coastal Chambers,
Buckingham Palace Road, S.W.1.

SEMICON-INF SERVICE

Suppliers of all types of INDUSTRIAL and ENTERTAINMENT semi-conductors. American and CONTINENTAL devices are our speciality. Send 9d. stamps for price lists.

TRANSISTORS—Extremely wide selection available.							
AC127	9/6	AUY10	47/-	OC140	19/-	2N404	4/8
ACY20	6/6	GET872	5/-	2G302	5/8	2N508	5/4
ACY22	6/-	OC45M	5/-	2G371	4/-	2N525	6/-
AF139	29/-	OC71	6/6	2G381	4/-	2N2613	6/5
ASZ21	19/6	OC81/D	8/-	2N395	3/10	2N3053	13/6

General Purpose RF/IF—2N2926 6/5—1T 200 Mc/s PT 200mV. Sets of 2-OC 81M and OC81DM—10/6 per matched set. Also available—RED SPOT TRANSISTORS—1/3 each or 11/- dozen.

MAIL ORDER ONLY PLEASE TERMS: C.W.O.
Please add 9d. P. & P. on all orders of less than £2. 6d. stamps with enquiries please. (Data sheets, etc.)

M. R. CLIFFORD & CO. (R)

66 OLD OSCOTT LANE, BIRMINGHAM, 22A.

J. B. LOWE 115 CAVENDISH ROAD MATLOCK, DERBYSHIRE

ALL ITEMS BRAND NEW

Morse keys, good, fully adjustable, 3/6. Rotary switches, all types from 2/- . Miniature pots, 1k, 50k, 1Meg., carbon, 2/- . Chokes of every type. Relays. Hundreds in stock, 6V, 12V and 24V, from 2/- .

Vibrators 12V, 4 pin, 6d.

Terminal boards all shapes and sizes, 6d. each, 10 for 4/- . A must for any construction work.

Dubilier 1,000mF 12V miniature electrolytics, 1/6; 15 for £1. Miniature colour-coded 1/4W resistors, 2d.; 100 for 15/-, your choice. Lots of miniature ceramics, etc., ideal for transistor work, from 2d. Power Supplies: 250 V.a.c. or 12 V.d.c. in; 12.6 V.a.c. and 175 V.d.c. out. Brand new Marconi, a beautiful rugged bench supply at an incredible £2.10.0. Transistor supply. 250 V.a.c. in, 10 volts zener diode regulated out. Brand new, modern, miniature for 30/- .

Mullard OC201 transistors 15/- . Texas Instruments 2G381 3/- . 10 volt zener diodes 6/- .

Lots of other good buys in components, receivers, transmitters, test gear, etc. A s.a.e. will get you my latest price list. Orders over £1, POST FREE; 5/- and under, add 2/-; 10/- and under, add 3/- . £1 and under add 4/- .

YUKAN SELF-SPRAY

Get this Air-drying Grey
HAMMER FINISH
NOW—

IT'S SUPERB THE PUSHBUTTON WAY !

YUKAN Aerosol spraykit contains 16 ozs. fine quality durable easy instant spray. No stove baking required. Available in Grey Hammer at 14/11 at our counter or 15/11, carr. paid, per pushbutton self-spray can. SPECIAL OFFER: I can plus optional transferable snap-on trigger handle (value 5/-) for 18/11. Please enclose cheque or P.O. for total amount to:



YUKAN

Dept. RC/9 307a EDGWARE ROAD LONDON W.2

(Closed Thursday afternoons, open all day Saturdays)

Choice of 13 self-spray plain colours and primer (motor car quality) also available

THE RADIO CONSTRUCTOR — BOUND VOLUMES

NOW AVAILABLE

Volume 18, August 1964 to July 1965. Price £1 10s. 0d. Postage 3s. 6d.

Where all issues are returned: Price £1. Postage 3s. 6d.

Limited number of Volume 17, August 1963 to July 1964 still available, same prices as above.

We regret earlier volumes now sold out.

Send for our latest brochure containing details of our other publications

DATA PUBLICATIONS LTD 57 MAIDA VALE LONDON W9

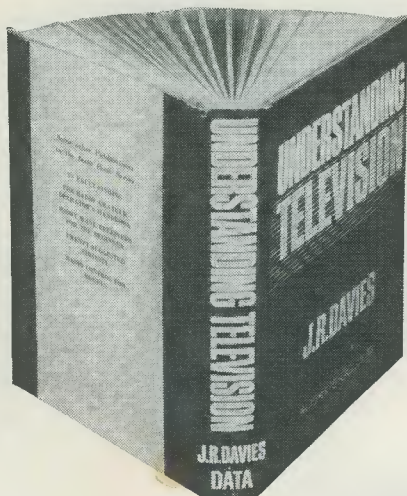

UNDERSTANDING TELEVISION

by

J. R. Davies

512 pages

299 diagrams

37/6

UNDERSTANDING TELEVISION deals with the principles of 625 line reception as fully as 405 line reception, and explains in detail: the nature of the television signal; the cathode ray tube; receiver tuner units; receiver i.f. amplifiers; a.f. and video amplifiers; vertical and horizontal timebases; deflector coil assemblies; synchronising; automatic gain and contrast control; power supplies and receiver aerials. There is also a very comprehensive section dealing with present-day colour television.

The reader is required to have only a basic knowledge of elementary radio principles. The treatment is non-mathematical throughout, and there is no necessity for any previous experience in television whatsoever. At the same time, UNDERSTANDING TELEVISION is of equal value to the established engineer because of the very extensive range it covers and the factual information it provides.

Some Recent Reviews

"An extremely well written book which will be useful to anybody who wishes to gain or consolidate knowledge on the practical aspects of television . . ."—*British Communications & Electronics*.

"The text is well written, the diagrams well drawn and to the point, and the printing is good. Apprentices and all service engineers who wish to obtain a greater grasp of this subject will find this book very useful. . . ."—*Radio & Electrical Retailing*.

"The author goes very fully into the circuitry and theory of receiver design, and his technical explanations are easy to understand. . . ."—*Wireless & Electrical Trader*.

"The treatment is entirely non-mathematical and should be well suited to anyone who has a reasonable knowledge of radio theory. The text is profusely illustrated with diagrams and explanatory captions succinctly hammer home the relevant points—a valuable supplementary to the main text. . . ."

—*Practical Television*.

To Data Publications Ltd., 57 Maida Vale, London, W9

Please supply.....copy(ies) of your latest publication "Understanding Television", Data Book No. 17. Price 37/6. Postage 2/6.

NAME.....

ADDRESS

.....

.....

FULLY DETAILED AND ILLUSTRATED
CATALOGUE

Now 96 big pages. The largest range available in the country. All types of components and equipment at competitive prices.

PRICE 2/6 (post paid)

PROVED & TESTED DESIGNS

FULL AFTER SALES SERVICE AND GUARANTEE

★ CALL IN FOR DEMONSTRATIONS ★

DETAILED LEAFLETS FREE ON REQUEST



MW/LW POCKET SUPERHET

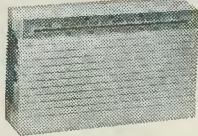

RADIO

TOTAL COST TO BUILD
85/- P.P. 2/-
(Battery 2/6 Phone 5/-)

★ All parts sold separately.

- ★ 6-Transistor design. Push-pull output.
- ★ 2½" Clearstone speaker. Printed circuit.
- ★ Attractive moulded cabinet.
- ★ Low motion tuning.
- ★ Full medium and long waves.
- ★ Size: 5" x 3" x 1¼"

● **AMAZING SENSITIVITY AND SELECTIVITY** ●

- ★ 6-Transistor push-pull design.
- ★ Uses factory built panels.
- ★ Permeability geared tuning.
- ★ Full med./long wave tuning with push-button wave change.
- ★ Double tuned IFT's.
- ★ Chromed front panel plate.
- ★ Size: 7" x 4" x 2". Fits any car.
- ★ Pre-built units sold separately.

TOTAL COST TO BUILD

£8.19.6
P.P. 3/6

(7" x 4" speaker with car fixing kit and baffle board 20/- extra.)

TWO WAVEBAND ALL-TRANSISTOR CAR RADIO TO ASSEMBLE

● **HIGH PERFORMANCE SUPERHET** ●

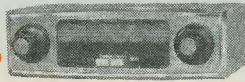

2- AND 4-TRACK TAPE RECORDERS TO ASSEMBLE

Pre-built Equipment—6 Valves—Collaro Studio Decks—Portable Cabinets with Speakers. Complete record and playback.

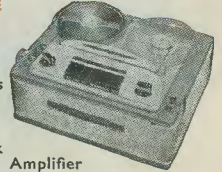

★ 2-track deck
10 gns. P.P. 5/- Amplifier
11 gns. Cabinet with speaker 5 gns.

OR SPECIAL PRICE **£26** P.P. 8/6

★ 4-track deck £13.19.6. P.P. 5/- Amplifier
12 gns. Cabinet with speaker 5 gns.

OR SPECIAL PRICE **£30** P.P. 8/6 **FOUR TRACK**

10W & 20W HI-FI AMPLIFIERS

Prebuilt and tested units. Low distortion, low noise.

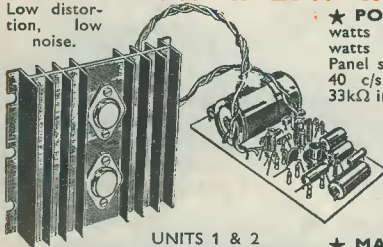

UNITS 1 & 2

★ **POWER AMPLIFIERS.** 10 watts R.M.S. music power. 20 watts peak. 6-Transistor design. Panel size 4" x 2½" x 3". Response 40 c/s to 20 kc/s. 100mV into 33kΩ input.

UNIT 1. For 12/15 ohm speakers. 40 volt supply.

PRICE BUILT **£5.19.6** P.P. 2/6

UNIT 2. For 3 to 5 ohm speakers. 24/28 volt supply.

PRICE BUILT **£5.10.0** P.P. 2/6

★ **MAINS UNITS.** 59/6. To power one amplifier or 69/6 to power two amplifiers. (State 24 or 40 volt version.)

PREAMPLIFIERS. Mono and stereo versions. 8 inputs, 1½ to 300mV at 1k to 500k. Response 30 c/s to 20 kc/s. Complete range of controls. Mains unit or battery operated. For pick-ups, tuners, tape, microphones, etc.

UNIT 3. Mono, full-function pre-amplifier. Size 9½" x 2½" x 2".

PRICE BUILT **£5.10.0** P.P. 2/-

(Brown/Gold front panel plate 8/6)

UNIT 4. Simplified version of Unit 3. Price 65/- P.P. 1/6. Panel plate 6/6.

UNIT 5. Stereo preamplifier for use with two units 1 or 2. Size 9" x 3½" x 1½".

PRICE BUILT **£10.19.6** P.P. 3/6

(Front panel plate 12/6)



UNIT 5

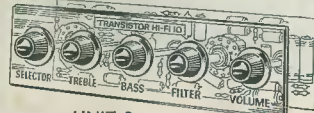

UNIT 3

THE FINEST QUALITY HI-FI AT UNBEATABLE PRICES

- We stock:
- TRANSISTORS
 - RECTIFIERS
 - VALVES
 - CRYSTALS
 - MICROPHONES
 - TEST GEAR
 - TAPE DECKS
 - SPEAKERS
 - MULTI-METERS
 - RADIO CONTROL AMPLIFIERS
 - RECORDERS
 - TUNERS
 - RECORD DECKS
 - TWEETERS
 - RECEIVERS
 - GENERATORS
 - COMPONENTS AND ACCESSORIES
- SEE LATEST CATALOGUE

SINGULAR DESIGNS

- ★ Micro-6 MW radio 59/6
- ★ TR750 "Addon" power amp. 39/6
- ★ Micro injector 27/6
- ★ Micro amp. 28/6
- ★ X10 Amp. kit £5.19.6

NEW X 20 AMPLIFIER

Kit £7.19.6

Built £9.19.6

Mains unit 99/6

5 WATT AND 1½ WATT PACKAGED AMPLIFIERS

- ★ 6-Transistor push-pull printed circuit designs
- ★ Size only 2½" x 2" x 1½"
- ★ 5 watt 18 volt, 1½ watt 12 volt
- ★ For 3 to 5 ohm speakers
- ★ 7mV into 1kΩ 30 kc/s to 16 kc/s

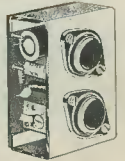

PRICES BUILT 1½w 65/- P.P. 1/6 5w 79/6 P.P. 1/6

4-CHANNEL MICROPHONE MIXER

Transistorised, 4 inputs up to 100 kΩ. Full mixing. PRICE **49/6** P.P. 1/6

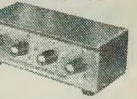

Let us quote for parts for your circuit. Send a list for quick reply. Quality components at realistic prices.

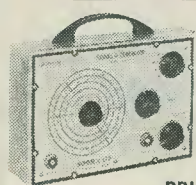

TRANSISTOR PORTABLE TEST EQUIPMENT

All units size 6½" x 4½" x 2½"
★ RF generator, 150 kc/s to 350 mc/s in 8 ranges. RF, Mod. RF, AF outputs.

PRICE **£9.10.0** P.P. 2/6

- ★ Resistance/capacitance bridge. £8.5.0.
- ★ Audio generator 10 c/s-100 kc/s. 4 ranges. £16.15.0. P.P. 2/6.



VHF/FM TUNER TO ASSEMBLE

★ Two pre-built plus metal work and front panel.
Total Cost **£12.17.6**
P.P. 2/6

- ★ Size: 9½" x 3½" x 4"
- ★ 88 to 108 mc/s tuning.
- ★ 100mV to 100kΩ output
- ★ 6-Transistor printed cct. superhet design

NEW SW/MW/LW PUSH-BUTTON PORTABLE TO BUILD. 3 wavebands

TOTAL COST **£8.19.6**
P.P. 3/6

The only fully Tunable 3-waveband radio for home construction.

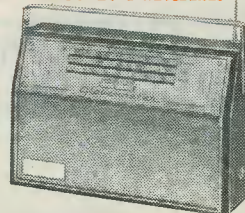

- ★ Push-button coil pack.
- ★ 1 watt push-pull output
- ★ Ferrite aerial/Telex. aerial/special car coils
- ★ Printed circuit 6-transistor design
- ★ SW 17/50m. LW 1100/1900m. MW 195/550m.
- ★ Car aerial and tape sockets
- ★ Attractive sturdy cabinet with handle. Size 11" x 7½" x 3½". Black fabric with chrome fittings.

SENSITIVE SUPERHET RADIO TO BUILD

● Two waveband version as previously advertised still available £7.19.6, pp. 3/6.

VHF/FM TRANSISTOR TUNER TO BUILD

TOTAL COST **£6.19.6**

P.P. 2/6 (complete with frontplate) (Gold sprayed cabinet 20/- extra).

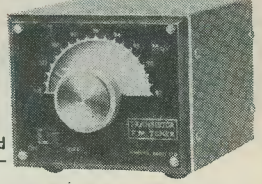

- ★ 5-Transistor 4 diodes.
- ★ Printed circuit superhet.
- ★ Geared tuning 87 to 105 Mc/s FM
- ★ RF stage and double tuned IFT's.
- ★ Output up to 1 volt peak up to 100kΩ.
- ★ 9 volt 9mA supply.
- ★ Size in cabinet 4" x 3½" x 2½".
- ★ All parts sold separately.

HENRY'S RADIO LTD.

303 EDGWARE ROAD, LONDON, W2
PADddington 1008/9

Open Mon. to Sat. 9-6. Thurs. 1 p.m.
Open all day Saturday